

# HYDRAULIC POWER UNITS (HPU) 3520 SERIES

The Perfect Partner for Your Servohydraulic Test System

Instron® introduces its new series of HPUs. At last you have the ability to configure an HPU to meet all your testing requirements and site conditions with unsurpassed efficiency and low environmental impact.

The HPUs range from 13 liters/min to 118 liters/min (3.4 gallons/min to 31.2 gallons/min) with nominal operating pressures of 207 bar (3000 psi) and 280 bar (4060 psi). The HPU has been designed with the environment very much in mind. Through careful selection of components and materials, Instron is able to provide an optional acoustic attenuation package with unsurpassed noise reduction, allowing the HPU to be positioned close to the test machine.

## FEATURES AND BENEFITS

- Pressure compensated variable flow pump configuration
- High efficiency Class 1 motor
- Programmable Logic Controller (PLC)
- Fully adjustable supply pressure
- 2  $\mu\text{m}$  pressure line filtration
- A wide range of available flow rates to suit every conceivable single and multi-station test configuration
- A choice of local control (at HPU) or remote control from your Instron controller
- High oil tank volume to flow rate ratios



## STANDARD OPERATION

To complement the advanced range of standard features all 3520 series HPUs can be factory fitted with a number of options to meet specific site conditions.

### Acoustic Attenuation

Instron has combined close attention to detail and superior materials selection to produce an acoustic attenuation package with outstanding performance. The system features fully integrated electronics and is designed for ease of installation and servicing. Motor access is simplified by the non-submerged design.

### Accumulation

Bladder-type pressure accumulators are available to smooth pump ripples and minimize ring main disturbance with rapidly changing system demands.

### Air Cooling

Remote air-blast cooling units are available for installations where water cooling is not desirable. The cooling units are designed for ambient air temperatures of up to +37 °C (+98 °F) and are compatible with all 3520 series HPUs.

## PLC OPERATOR INTERFACE

All models feature a fully integrated Programmable Logic Controller (PLC) with conveniently positioned operator interface panel. The PLC provides powerful control features in combination with the advanced circuitry of the 3520 series HPUs.



PLC operator interface

## SPECIFICATIONS

Catalog Number		3521-027	3521-048	3521-078	3521-118
Flow Rates at 207 bar on 50/60 Hz	l/min	27	48	78	118
	GPM	7.1	12.7	20.6	31.2
Operating Pressure	bar	207	207	207	207
	psi	3000	3000	3000	3000
Maximum Output Pressure at Reduced Flow	bar	230	230	230	230
	psi	3336	3336	3336	3336
Reservoir Capacity, Full	liters	150	260	600	600
	gal	40	69	159	159
Standard Filtration Level - Pressure/Return	µm	2	2	2	2
System Management		PLC	PLC	PLC	PLC
Motor Starter Configuration		Star-delta	Star-delta	Star-delta	Star-delta
Motor Size	kW	11	18.5	30	45
	hp	14.8	24.8	40.2	60.3
Pump Type		Variable displacement	Variable displacement	Variable displacement	Variable displacement
Heat Exchanger		St/ steel plate type	St/ steel plate type	St/ steel plate type	St/ steel plate type
Noise Level at 1 m*	dB (A)	58	60	63	63
Depth (D)	mm	823	890	1140	1140
	in	32.4	35	44.9	44.9
Height (H)	mm	1270	1370	1660	1660
	in	50	53.9	65.4	65.4
Width (W)	mm	1130	1460	1740	1740
	in	44.5	57.5	68.5	68.5
Dry Weight	kg	620	830	1400	1480
	lb	1376	1830	3086	3236
Weight with Maximum Oil	kg	751	1056	1922	2002
	lb	1655	2329	4237	4414
Noise Level at 1 m*	dB (A)	72	73	76	76
Depth (D)	mm	810	900	1110	1110
	in	31.9	35.4	43.7	43.7
Height (H)	mm	1340	1500	1670	1670
	in	52.8	59.1	65.7	65.7
Width (W)	mm	1130	1435	1740	1740
	in	44.5	56.5	68.5	68.5
Dry Weight	kg	480	620	1010	1130
	lb	1058	1376	2227	2491
Weight with Maximum Oil	kg	611	846	1532	1651
	lb	1456	1866	3377	3642

\*Acoustic attenuation system providing noise levels of 58 dB(A) - 63 dB(A)

Models with  
Acoustic Attenuation

Models without  
Acoustic Attenuation

## SPECIFICATIONS

Catalog Number		3528-028	3528-041	3528-086
Flow Rates at 207 bar on 50/60 Hz	l/min	28	41	86
	GPM	7.4	10.8	22.7
Operating Pressure	bar	280	280	280
	psi	4060	4060	4060
Maximum Output Pressure at Reduced Flow	bar	315	315	315
	psi	4569	4569	4569
Reservoir Capacity, Full	liters	150	260	600
	gal	40	69	159
Standard Filtration Level - Pressure/Return	µm	2	2	2
System Management		PLC	PLC	PLC
Motor Starter Configuration		Star-delta	Star-delta	Star-delta
Motor Size	kW	15	22	45
	hp	20.1	29.5	60.3
Pump Type		Variable displacement	Variable displacement	Variable displacement
Heat Exchanger		St/ steel plate type	St/ steel plate type	St/ steel plate type
Noise Level at 1 m*	dB (A)	60	60	63
Depth (D)	mm	823	890	1140
	in	32.4	35	44.9
Height (H)	mm	1270	1370	1660
	in	50	53.9	65.4
Width (W)	mm	1130	1460	1740
	in	44.5	57.5	68.5
Dry Weight	kg	660	870	895
	lb	1455	1918	3263
Weight with Maximum Oil	kg	791	1096	2002
	lb	1734	2417	4414
Noise Level at 1 m*	dB (A)	73	74	78
Depth (D)	mm	810	900	1110
	in	31.9	35.4	43.7
Height (H)	mm	1340	1500	1670
	in	52.8	59.1	65.7
Width (W)	mm	1130	1435	1740
	in	44.5	56.5	68.5
Dry Weight	kg	530	660	1130
	lb	1168	1455	2491
Weight with Maximum Oil	kg	661	886	1651
	lb	1456	1954	3642

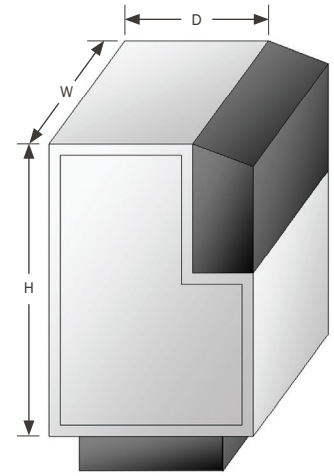

Dimensions

Models with  
Acoustic Attenuation

Models without  
Acoustic Attenuation

\*Acoustic attenuation system providing noise levels of 60 dB(A) - 63 dB(A)

Note: dB (A) is a measurement of the sound pressure level (units Decibel, dB), weighted to suit the normal frequency response of the human ear. It is expressed in free field (open) conditions, and therefore readings may vary within the installed environment.

[www.instron.com](http://www.instron.com)



Worldwide Headquarters  
825 University Ave, Norwood, MA 02062-2643, USA  
Tel: +1 800 564 8378 or +1 781 575 5000

European Headquarters  
Coronation Road, High Wycombe, Bucks HP12 3SY, UK  
Tel: +44 1494 464646

CEAST Headquarters  
Via Airauda 12, 10044 Pianezza TO, Italy  
Tel: +39 011 968 5511