

AXIAL TORSION TEST SYSTEM

BI-7050

BI-7050 Axial-Torsion Servo-Hydraulic Testing System meets the challenging demands of various static and dynamic test requirements. The system carries out axial, torsion, or combined axial-torsion tests. With the actuator in the upper crosshead and a lower t-slot table, the system makes an ideal platform for testing a variety of medical devices, biomaterials, advanced materials, and other components testing.

FEATURES

- Twin column high stiffness, precision aligned load frame with actuator mounted on top movable crosshead
- Double-acting servo-hydraulic actuator with force capacity up to ± 25 kN and torque capacity of ± 250 Nm
- 100 mm of usable axial stroke and $\pm 45^\circ$ of rotation
- Designed for both dynamic and static testing on a variety of materials and components
Choice of hydraulic configuration and dynamic performance to suit application
- Extra-height frame option for testing longer load strings
Adjustable upper crosshead with hydraulic lifts and manual locks fitted as standard for easy adjustment of daylight
- Electronically servo-controlled variable flow, variable pressure, low noise, energy efficient pump
- Digital servo controller with 6 kHz, 32-bit digital closed loop control and 24 bit data acquisition
- User friendly MTL-windows software with dedicated application software

APPLICATIONS

- Tensile, compression, LCF, fracture mechanics clevis for crack growth and fracture toughness studies or flexure fixtures for bend tests
- System is also suitable to test under high or low temperatures and with customized grips to test complex specimen geometries



Specifications

		BI-7051	BI-7052	BI-7053
Dynamic Load Capacity	kN	25	50	100
Configuration		Top mount actuator	Bottom mount actuator	
Torsional Capacity	Nm	250	1000	2000
Actuator Total Stroke	mm	150		
Angle of Rotation	mm	±45 deg with a tolerance of ± 5 deg.C		
Frame Stiffness	kN/mm	500	1000	2000
Loadcell Accuracy		+/-0.5% down to 1/500 th of loadcell capacity		
Column Clearance	mm	600	600	600
*Daylight Opening	mm	1200	1500	1500
System Dimensions H x W x D	mm	2950 x 1260 x 1100	3250 x 1400 x 1400	3250 x 1400 x 1400
Max. Frame Weight	kg	1500	1600	1800

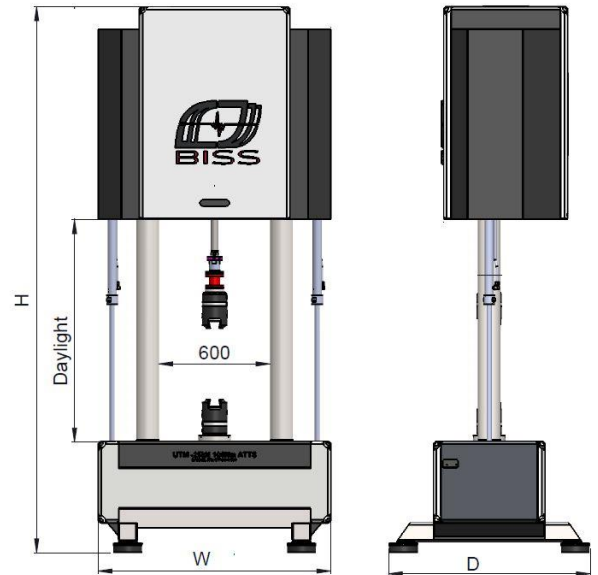

NOTE

Please refer to individual brochures for information on the selected power packs & accessories
 Custom configurations available
 CE certification on Demand
 Specifications are subject to change without prior notice

www.instron.com



Worldwide Headquarters
 825 university Ave, Norwood MA 02062 – 2643, USA
 Tel: +1 800 564 8378 or +1 781 575 5000

India Headquarters
 #497 E, 14th Cross, 4th Phase, Peenya Industrial Area,
 Bangalore – 560058, India.
 Tel: +91 80 283 60184 Fax: +91 80 283 60047

Instron is a registered trademark of Illinois Tool Works Inc. (ITW). Other names, logos, icons and marks identifying Instron products and services referenced herein are trademarks of ITW and may not be used without the prior written permission of ITW. Other product and company names listed are trademarks or trade names of their respective companies. Copyright © 2016 Illinois Tool Works Inc. All rights reserved. All of the specifications shown in this document are subject to change without notice.