

## 2717 SERIES TENSION GRIPS

The o-ring test fixture has been designed to facilitate the testing of o-rings and similar continuous loop specimens where it is essential to minimize localized stressing in the sample.

### PRINCIPLE OF OPERATION

The fixture, which is easily fitted to Instron single or dual column testing machines, consists of an upper and lower frame. The upper frame mounts into a standard load cell coupling and contains a bearing mounted roller. The lower frame is mounted in a standard base adapter and also carries a bearing mounted roller. The specimen is rotated by the lower roller. The lower roller is rotated, via a drive sprocket, by a timing belt coupled to the moving crosshead. The rotation speed of the lower spindle can be selected by moving the toothed belt from one pulley to another.

### FEATURES AND BENEFITS

- Universal design with optional, interchangeable, spindle sets to meet a range of standards
- 1 kN (100 kgf, 220 lbf) load capacity
- Lower spindle driven from crosshead motion
- Easily selectable rotation speed via toothed-belt drive
- Optional spindle sets for: ASTM D1414, BS 3704 (includes additional drive pulleys), DIN 53504, general purpose 3.175 mm (0.125 in), 6.35 mm (0.25 in), and 12.7 mm (0.5 in) diameter
- Ambient temperature use only

### APPLICATION RANGE

- O-ring testing
- Other continuous specimens



2717-078 on Dual Column machine

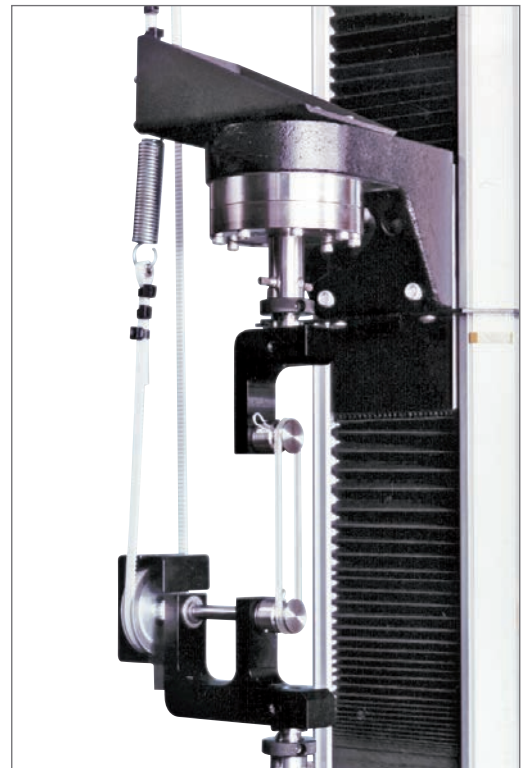

2717-068 on Single Column Machine

## SPECIFICATIONS

Catalog Number	-	2717-068	2717-078	2717-079
Compatible Machines	-	Single Column Systems: 3343, 3345, 4443, 4444, 5543, 5544, 5843, 5844, 5943, 5944	Standard Height System (E1 option): 3365, 3366, 3367, 3369, 4464, 4465, 4466, 4467, 4469, 5564, 5565, 5566, 5567, 5569, 5864, 5865, 5866, 5867, 5869, 5965, 5966, 5967, 5969, 34TM-5, 34TM-10, 34TM-30, 34TM-50, 68TM-5, 68TM-10, 68TM-30, 68TM-50	Extra Height Systems (E2 option): 3365, 3366, 3367, 3369, 4464, 4465, 4466, 4467, 4469, 5564, 5565, 5566, 5567, 5569, 5864, 5865, 5866, 5867, 5869, 5965, 5966, 5967, 5969, 34TM-5, 34TM-10, 34TM-30, 34TM-50, 68TM-5, 68TM-10, 68TM-30, 68TM-50
	Maximum Capacity	kN kgf lbf	1 100 220	1 100 220

## MECHANICAL CONNECTION

Upper Fitting	-	6 mm clevis pin (Type Om)	6 mm clevis pin (Type Om)	6 mm clevis pin (Type Om)
Lower Fitting	-	6 mm clevis pin (Type Om)	0.5 in clevis pin (Type Dm)	0.5 in clevis pin (Type Dm)

## WIDTH (A)

Upper	mm	106	106	106
	in	4.2	4.2	4.2
Lower	mm	135	140	140
	in	5.4	5.55	5.55

## EFFECTIVE LENGTH (B)

Upper	mm	90	90	90
	in	3.55	3.55	3.55
Lower	mm	90	108	108
	in	3.55	4.3	4.3
Weight	kg	3.3	3.4	3.4
	lb	7.25	7.5	7.5
Temperature Range	-	Ambient use only		

## Notes:

- Require spindle set.

## ACCESSORIES

Catalog Number		Description	Roller Diameter d1	Roller Width d2
2717-070	mm	4.75 diameter	4.75	7
	in	0.19 diameter	0.19	0.28
2717-071	mm	To BS 3704	15	25
	in		0.59	0.98
2717-072	mm	To DIN 53504 R1	22.3	7
	in		0.88	0.28
2717-073	mm	To DIN 53504 R2	18.3	7
	in		0.72	0.28
2717-074	mm	3.175 diameter	3.18	7
	in	0.125 diameter	0.125	0.28
2717-075	mm	6.35 diameter	6.35	7
	in	0.25 diameter	0.25	0.28
2717-076	mm	To ASTM D1414	12.7	7
	in		0.5	0.28

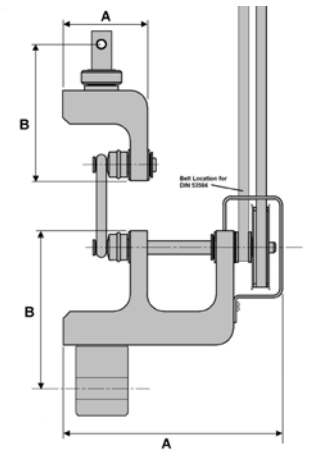

O-ring fixture dimensions

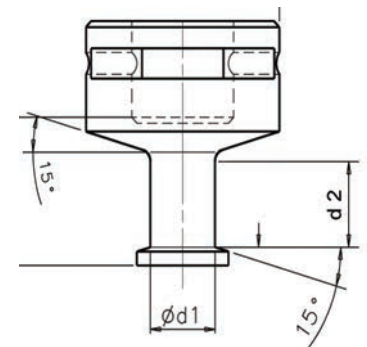

Spindle Dimensions

[www.instron.com](http://www.instron.com)

Worldwide Headquarters  
825 University Ave, Norwood, MA 02062-2643, USA  
Tel: +1 800 564 8378 or +1 781 575 5000

European Headquarters  
Coronation Road, High Wycombe, Bucks HP12 3SY, UK  
Tel: +44 1494 464646