



3400 Series Dual Column Table Model



Operator's Guide

M10-17318-EN Revision F

Proprietary Rights Notice

This document and the information that it contains are the property of Illinois Tool Works Inc. (ITW). Rights to duplicate or otherwise copy this document and rights to disclose the document and the information that it contains to others and the right to use the information contained therein may be acquired only by written permission signed by a duly authorized officer of ITW.

Trademarks

Instron[®] is a registered trademark of Illinois Tool Works Inc. (ITW). Other names, logos, icons and marks identifying Instron products and services referenced herein are trademarks of ITW and may not be used without the prior written permission of ITW.

Other product and company names listed are trademarks or trade names of their respective companies.

Original Instructions

Copyright © 2019 Illinois Tool Works Inc. All rights reserved. All of the specifications shown in this document are subject to change without notice.

Worldwide Headquarters

Instron
825 University Avenue
Norwood, MA 02062-2643
United States of America

European Headquarters

Instron
Coronation Road
High Wycombe, Bucks HP12 3SY
United Kingdom

General Safety Precautions



Materials testing systems are potentially hazardous.

Materials testing involves inherent hazards from high forces, rapid motions, and stored energy. You must be aware of all moving and operating components in the testing system that are potentially hazardous, particularly force actuators or a moving crosshead.

Carefully read all relevant manuals and observe all Warnings and Cautions. The term Warning is used where a hazard may lead to injury or death. The term Caution is used where a hazard may lead to damage to equipment or to loss of data.

Instron products, to the best of its knowledge, comply with various national and international safety standards, in as much as they apply to materials and structural testing. We certify that our products comply with all relevant EU directives (CE mark).

Because of the wide range of applications with which our instruments are used, and over which we have no control, additional protection devices and operating procedures may be necessary due to specific accident prevention regulations, safety regulations, further EEA directives or locally valid regulations. The extent of our delivery regarding protective devices is defined in your initial sales quotation. We are thus free of liability in this respect.

At your request, we will gladly provide advice and quotations for additional safety devices such as protective shielding, warning signs or methods of restricting access to the equipment.

The following pages detail various general warnings that you must heed at all times while using materials testing equipment. You will find more specific Warnings and Cautions in the text whenever a potential hazard exists.

Your best safety precautions are to gain a thorough understanding of the equipment by reading your instruction manuals and to always use good judgement.

It is our strong recommendation that you should carry out your own product safety risk assessment.

Warnings



Hazard - Press the Emergency Stop button whenever you consider that an unsafe condition exists.

The Emergency Stop button removes hydraulic power or electrical drive from the testing system and brings the hazardous elements of the system to a stop as quickly as possible. It does not isolate the system from electrical power, other means are provided to disconnect the electrical supply. Whenever you consider that safety may be compromised, stop the test using the Emergency Stop button. Investigate and resolve the situation that caused the use of the Emergency Stop button before you reset it.



Flying Debris Hazard - Make sure that test specimens are installed correctly in grips or fixtures in order to eliminate stresses that can cause breakage of grip jaws or fixture components.

Incorrect installation of test specimens creates stresses in grip jaws or fixture components that can result in breakage of these components. The high energies involved can cause the broken parts to be projected forcefully some distance from the test area. Install specimens in the center of the grip jaws in line with the load path. Insert specimens into the jaws by at least the amount recommended in your grip documentation. This amount can vary between 66% to 100% insertion depth; refer to supplied instructions for your specific grips. Use any centering and alignment devices provided.



Hazard - Protect electrical cables from damage and inadvertent disconnection.

The loss of controlling and feedback signals that can result from a disconnected or damaged cable causes an open loop condition that may drive the actuator or crosshead rapidly to its extremes of motion. Protect all electrical cables, particularly transducer cables, from damage. Never route cables across the floor without protection, nor suspend cables overhead under excessive strain. Use padding to avoid chafing where cables are routed around corners or through wall openings.

Warnings



High/Low Temperature Hazard - Wear protective clothing when handling equipment at extremes of temperature.

Materials testing is often carried out at non-ambient temperatures using ovens, furnaces or cryogenic chambers. Extreme temperature means an operating temperature exceeding 60 °C (140 °F) or below 0 °C (32 °F). You must use protective clothing, such as gloves, when handling equipment at these temperatures. Display a warning notice concerning low or high temperature operation whenever temperature control equipment is in use. You should note that the hazard from extreme temperature can extend beyond the immediate area of the test.



Crush Hazard - Take care when installing or removing a specimen, assembly, structure, or load string component.

Installation or removal of a specimen, assembly, structure, or load string component involves working inside the hazard area between the grips or fixtures. When working in this area, ensure that other personnel cannot operate any of the system controls. Keep clear of the jaws of a grip or fixture at all times. Keep clear of the hazard area between the grips or fixtures during actuator or crosshead movement. Ensure that all actuator or crosshead movements necessary for installation or removal are slow and, where possible, at a low force setting.



Hazard - Do not place a testing system off-line from computer control without first ensuring that no actuator or crosshead movement will occur upon transfer to manual control.

The actuator or crosshead will immediately respond to manual control settings when the system is placed off-line from computer control. Before transferring to manual control, make sure that the control settings are such that unexpected actuator or crosshead movement cannot occur.



Robotic Motion Hazard - Keep clear of the operating envelope of a robotic device unless the device is de-activated.

The robot in an automated testing system presents a hazard because its movements are hard to predict. The robot can go instantly from a waiting state to high speed operation in several axes of motion. During system operation, keep away from the operating envelope of the robot. De-activate the robot before entering the envelope for any purpose, such as reloading the specimen magazine.

Warnings



Hazard - Set the appropriate limits before performing loop tuning or running waveforms or tests.

Operational limits are included within your testing system to suspend motion or shut off the system when upper and/or lower bounds of actuator or crosshead travel, or force or strain, are reached during testing. Correct setting of operational limits by the operator, prior to testing, will reduce the risk of damage to test article and system and associated hazard to the operator.



Electrical Hazard - Disconnect the electrical power supply before removing the covers to electrical equipment.

Disconnect equipment from the electrical power supply before removing any electrical safety covers or replacing fuses. Do not reconnect the power source while the covers are removed. Refit covers as soon as possible.



Rotating Machinery Hazard - Disconnect power supplies before removing the covers to rotating machinery.

Disconnect equipment from all power supplies before removing any cover which gives access to rotating machinery. Do not reconnect any power supply while the covers are removed unless you are specifically instructed to do so in the manual. If the equipment needs to be operated to perform maintenance tasks with the covers removed, ensure that all loose clothing, long hair, etc. is tied back. Refit covers as soon as possible.



Hazard - Shut down the hydraulic power supply and discharge hydraulic pressure before disconnection of any hydraulic fluid coupling.

Do not disconnect any hydraulic coupling without first shutting down the hydraulic power supply and discharging stored pressure to zero. Tie down or otherwise secure all pressurized hoses to prevent movement during system operation and to prevent the hose from whipping about in the event of a rupture.



Hazard - Shut off the supply of compressed gas and discharge residual gas pressure before you disconnect any compressed gas coupling.

Do not release gas connections without first disconnecting the gas supply and discharging any residual pressure to zero.

Warnings



Explosion Hazard - Wear eye protection and use protective shields or screens whenever any possibility exists of a hazard from the failure of a specimen, assembly or structure under test.



Wear eye protection and use protective shields or screens whenever a risk of injury to operators and observers exists from the failure of a test specimen, assembly or structure, particularly where explosive disintegration may occur. Due to the wide range of specimen materials, assemblies or structures that may be tested, any hazard resulting from the failure of a test specimen, assembly or structure is entirely the responsibility of the owner and the user of the equipment.



Hazard - Ensure components of the load string are correctly pre-loaded to minimize the risk of fatigue failure.

Dynamic systems, especially where load reversals through zero are occurring, are at risk of fatigue cracks developing if components of the load string are not correctly pre-loaded to one another. Apply the specified torque to all load string fasteners and the correct setting to wedge washers or spiral washers. Visually inspect highly stressed components such as grips and threaded adapters prior to every fatigue test for signs of wear or fatigue damage.

Table of Contents

Chapter 1: Introduction	13
System Description and Terminology	15
Components	18
Principle of Operation.....	19
Hardware Controls	19
Software	20
System Safety and Information Labeling	20
Conformity with EU directives	22
Product Support	23
Product Documentation	23
Location of your Preinstallation manual	23
Chapter 2: Risk reduction and safe use	25
Residual risks	25
Rapid crosshead motion	26
Pinching fingers between grip jaw faces.....	28
Impact of debris from breaking specimens	28
Collision Mitigation.....	29
Ingress Protection.....	29
Solid particle ingress	30
Liquid ingress	30
Operator Protection Overview	31
Chapter 3: Installation	33
Level the load frame.....	33
Power supply compatibility.....	34
Set the input voltage.....	36
System components.....	38
Dual column table model load frame	39
Connect the system components	45

Bluehill® Operator Dashboard	47
First time startup	50
Chapter 4: Function of controls	53
Power input connector	53
Emergency Stop button	54
Frame Control Panel	55
Bluehill® software	57
Home Screen	57
Operator Protection	59
Operating Modes	59
Move between modes	63
Jog at High Speed	66
Operator Protection Controls	67
Bluehill® Operator Dashboard	68
Basic touch functions	68
Touchscreen gestures	69
Chapter 5: Assemble the load string	71
Select a load cell	72
Before you begin	73
Install a load cell - 34TM load frames up to 50 kN capacity	74
Install a 2530 load cell (capacities 5 N through 5 kN)	75
Install a 2530-10kN load cell	77
Install a 2530 load cell (capacities 30kN and 50kN)	79
Install a load cell - 34TM-100 load frame only	81
Install a 2530 load cell (capacities 5 N through 100 N)	82
Install a 2530 load cell (capacities 500 N through 5 kN)	85
Install a 2530 load cell (capacities 10kN through 50kN)	87
Install a 2530 100 kN load cell	90
Adapters	91
Base adapters	91
Coupling adapters	96

Select Grips and Fixtures	97
Insert Jaw Faces into Grips	97
Install grips	97
Preload the load string	99
Unload the load string	101
Chapter 6: Testing specimens	103
Testing a sample	103
Testing with no interlock	104
Testing with an interlock	107
Create a new sample	110
Calibrate a transducer	111
Automatic calibration of a force or strain transducer	111
Manual calibration	112
Set the zero displacement point	115
Crosshead limit stops	115
Set the crosshead limit stops	116
Move Off a Crosshead Limit Stop	117
Set the limits for a transducer	117
Balance a transducer configuration	118
Stop a test	119
Emergency Stop Button	119
Crosshead Limit Switches	120
Software Event	121
Shut down the system	121
Turn the system off	121
Troubleshooting	121
A Software Transducer Limit Trips	121
A Crosshead Travel Limit Trips	122
You press the Emergency Stop button	122
Chapter 7: Maintenance	123
Preventive Maintenance	123
Daily Maintenance Checks	124

Preliminary Pages

Periodic Inspections	124
Cleaning.	125
Lubrication	125
Lubricate ballnuts	126
General Maintenance Procedures.	128
Test Limit Stops.	128
Replace a Fuse	129
Troubleshooting for Load Cells	130
Ancillary parts	130
Parts list	130
Index	133

Chapter 1

Introduction

• System Description and Terminology.....	15
• System Safety and Information Labeling.....	20
• Conformity with EU directives.....	22
• Product Support.....	23
• Product Documentation.....	23

These instructions are intended to get you started working with your testing system. They assume the following:

- you are an operator familiar with the operation of materials testing systems in general
- your system consists of a load frame with integral controller, a load cell, a set of manually-operated grips and Bluehill[®] test control software
- the system has been installed by an Instron[®] service engineer
- Bluehill[®] test methods that are appropriate for your testing requirements are available

These instructions include the following information:

- installing and connecting all the system components together (carried out by an Instron[®] service engineer for first-time installation)
- configuring the system before you start testing (carried out by an Instron[®] service engineer for first-time installation)
- routine maintenance of the system
- spare parts

Using these instructions you will be able to:

- check the interconnections between all elements of the basic system
- install the grips and preload the load string
- prepare a set of specimens (sample) for testing

- test the sample
- view the test results and print a test report.
- perform routine maintenance of the system

These instructions do not include the development of Bluehill® test methods. This is covered in more advanced training that can be provided by the Instron® Service and Training departments.

System Description and Terminology

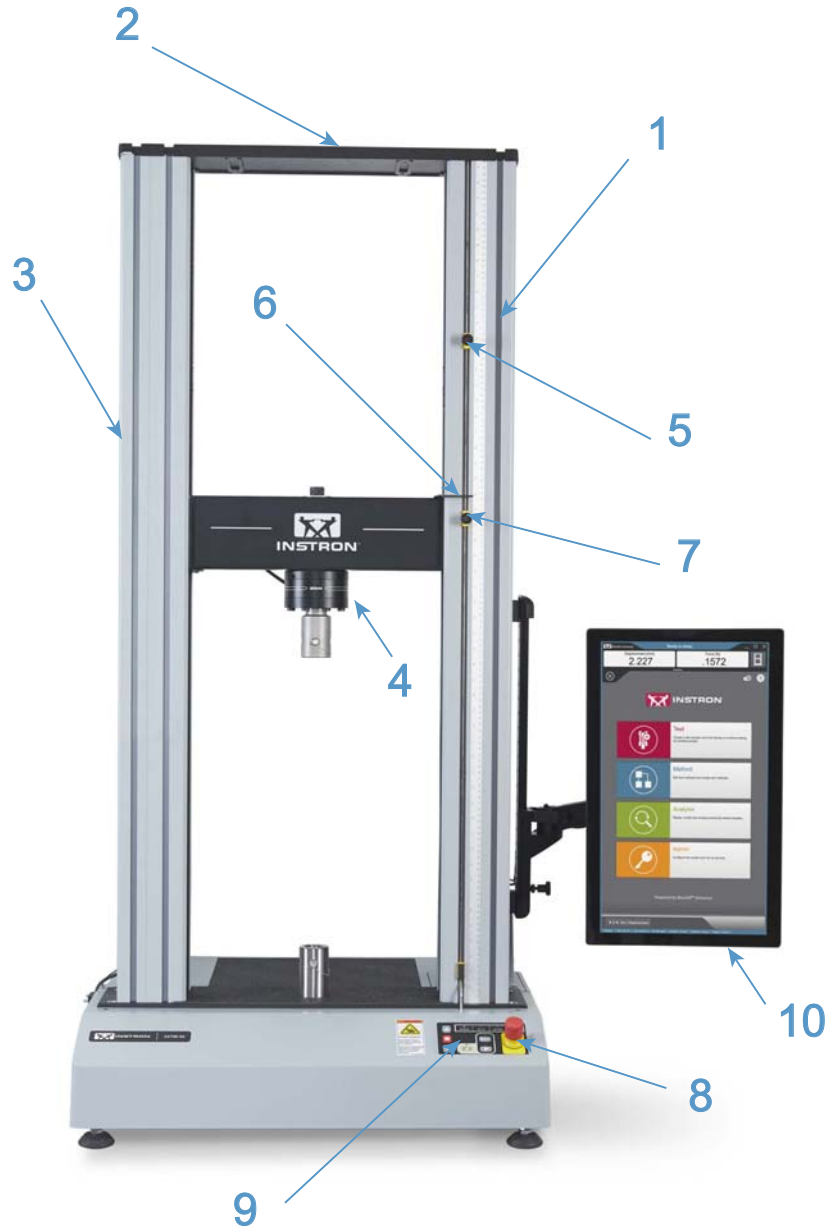

Figure 1. 3400 Dual Column Table Model with Bluehill® Operator Dashboard - Front View

Legend for [Figure 1](#)

Label	Component
1	T-slots
2	Top plate
3	Column cover
4	Load cell
5	Upper limit switch
6	Limit switch actuator
7	Lower limit switch
8	Emergency stop button
9	Frame control panel
10	Bluehill [®] Operator Dashboard (optional)

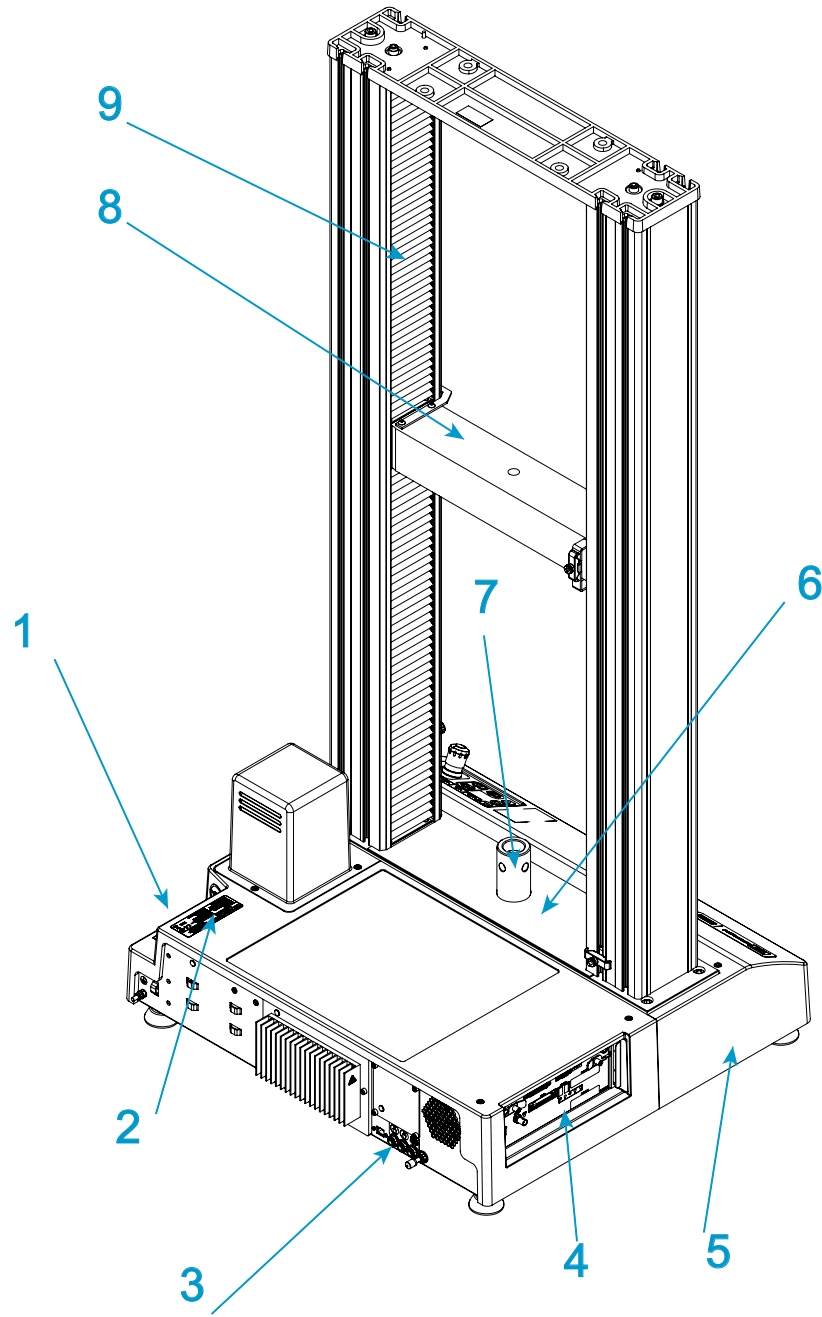

Figure 2. 3400 Dual Column Table Model - Rear View

Legend for Figure 2

Label	Component
1	Power inlet connection and power switch
2	System ID label
3	Rear panel
4	Controller panel
5	Frame base
6	Base beam
7	Base adapter
8	Crosshead
9	Ballscrew cover

Components

The major components of an Instron® electromechanical testing system include:

- Load frame with integral controller
- Load cell mounted to the crosshead
- Grips for tension testing or table-mounted anvils on a platen for compression testing.
- Instron® approved computer system with Instron Bluehill® software.

Special fixtures are available for applications such as flexure and peel testing. For strain measurement, an optional strain gauge extensometer attaches to the specimen. You can use non-contacting extensometers with specimens that are unable to support a contacting extensometer. Contact your regional Instron® office or check our web site at www.instron.com for assistance with Instron's grips and fixtures.

The following table defines the components of the testing system:

Table 1. Testing System Components

Component	Description
Load Frame	<p>The load frame comprises a base, one or two columns, a moving crosshead, and a top plate. It is a high stiffness support structure against which the test forces react.</p> <p>Each column comprises a guide column and a ballscrew. The crosshead is mounted on both the guide column and the ballscrew. Rotation of the ballscrew drives the crosshead up or down while the guide column provides stability.</p>
Controller	The hardware that controls the frame and any ancillary equipment connected to the testing system. The controller panel contains all the connectors for load cells, extensometers and any other sensors that are required for testing.
Frame Control Panel	This panel holds all of the controls and indicators for the testing system.
Load String	<p>Comprises all of the components that you install between the moving crosshead and the load frame base (or fixed crosshead). Typically this involves a load cell, a set of grips, any adapters that are required to connect the components, and the specimen to be tested.</p> <p>Typically, you mount a load cell on the crosshead, then a pair of grips or fixtures on the load cell and frame base. The grips or fixtures secure the specimen and when you start a test the crosshead moves up or down applying a tensile or compressive load to the specimen. The load cell converts this load into an electrical signal that the software measures and displays.</p>
Bluehill [®] Software	Instron [®] testing software that controls the testing system, running tests and analyzing test data to produce test results.
Specimen	A single piece of material to be tested.

Principle of Operation

The system communicates primarily through the controller. The controller contains sensor conditioning cards for the system transducers and transfers data between the transducers and the computer. The controller also communicates with the load frame via a Safety Monitoring Board (SMB) via a Break Out Board (BOB) inside the load frame. The Break Out Board links all the electrical components of the frame together.

Hardware Controls

The hardware controls consist of:

- Emergency stop button - to be used whenever you need to stop the crosshead immediately because an unsafe condition exists.

- Limit stops - these must be set before each test session to protect the operator and load string components against unexpected crosshead movement.
- Frame control panel - holds all the controls and indicators for the testing system.

Software

Control of the testing system is carried out via Instron Bluehill® software. Setting test parameters, operating the system, and collecting test data is done through the software program.

Table 2. Software Terminology

Term	Description
Test Method	In Bluehill® software, a test method is a file that contains a set of defined parameters that the system uses to run tests, analyze the test data, and produce calculated results.
Sample	A group of material specimens, whose properties are studied and compared to gain statistical or quality assurance information. For example, you could take a specimen from different parts of a single manufacturing run of a material to form a sample of the material. The sample is then representative of the complete run and you can test it to ensure that the material quality has remained stable over the complete run. You perform the same test on each specimen in a sample.

System Safety and Information Labeling

[Table 3](#) on page [20](#) explains the meanings of any safety and information labels that may be attached to any part of the testing system.

Table 3. Safety and Information Labeling Descriptions

Label	Meaning	Purpose
	Electrical hazard	Indicates that an electrical hazard exists from high voltage and/or electrical current.

Table 3. Safety and Information Labeling Descriptions (Continued)







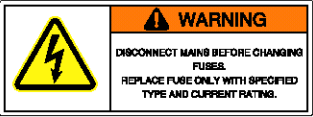

Label	Meaning	Purpose
	Disconnect power supply	Disconnect the power supply before servicing machine.
	Electrical - fuse warning	Indicates an electrical hazard exists. Advises disconnecting power mains before changing fuses and using only specified fuses.
	Belt entanglement hazard	Indicates that a hazard exists from the drive belt and pulley system.
	High temperature hazard	Indicates that a heat hazard exists. Stay clear of area when operating the machine.
	Rotating machinery hazard	Indicates that a rotating hazard exists. Keep clear of these areas (and tie back long hair and loose clothing).
	Ground stud	Indicates a ground stud.
	Read the manual	Read and understand the operator's manual before using the machine.
	Crosshead direction	Indicates the direction to turn the pulley to manually move the crosshead upward. Pulleys can be turned by hand when power is disabled.

Table 3. Safety and Information Labeling Descriptions (Continued)

Label	Meaning	Purpose
 <p>WARNING</p> <p>Crush hazard. Keep clear of test area when machine is in motion. Read and understand operator's manual before using this machine.</p>	Crush hazard	Indicates the crush hazard of the moving crosshead and instructs the user to read and understand the operator's manual before using the machine.
	Waste Electrical and Electronic Equipment (WEEE)	In accordance with the European Union's WEEE directive, the crossed out wheeled bin symbol indicates that the equipment must be disposed of separately from other waste at the end of its usable life. For advice on the disposal of electrical and electronic equipment in your country, contact your local Instron representative.

Conformity with EU directives

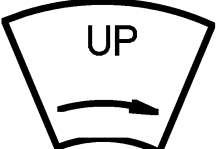
Instron[®] declares under our sole responsibility that 34SC and 34TM testing systems are in conformity with all relevant provisions of the following regulations:

- Machinery Directive 2006/42/EC
- EMC Directive 2014/30/EU
- ROHS Directive 2011/65/EU including substances added by amendment 2015/863/EU

Instron[®] testing systems are CE marked. A signed CE declaration of conformity is supplied with each system.

Product Support

Instron® provides documentation, including manuals and online help, that can answer many of the questions you may have. It is recommended that you review the documentation sent with the system you purchased for possible solutions to your questions.

If you cannot find answers in these sources, contact Instron® Service directly. A list of Instron® offices is available on our website at www.instron.com. In the US and Canada, you can call directly at 1-800-473-7838.

Product Documentation

Instron® offers a comprehensive range of documentation to help you get the most out of your Instron products. Depending on what you have purchased, your documentation may include some or all of the following:

Operator's Guide	How to use your system components and controls, procedures for setting limits, calibration and other frequently performed operating tasks. Information about system installation, set up and configuration, transducer connection and calibration. Routine maintenance and spare parts.
Preinstallation Manual	System requirements and specifications, instructions for lifting and handling to transport the system to its final location before installation.
Reference Help	Software products come complete with context sensitive help, which provides detailed information on how to use all software features.
Equipment Reference	How to set up and use any accessories you have purchased, for example grips, fixtures, extensometers, transducers, and environmental chambers.

We welcome your feedback on any aspect of the product documentation. Please email info_dev@instron.com with your comments.

Location of your Preinstallation manual

A copy of the Preinstallation manual for your model was sent upon receipt of your order to assist you to prepare for the arrival of your shipment.

You can find a copy of the Preinstallation manual on the USB drive provided with your system. This drive contains your Bluehill® software.

The Preinstallation manuals are stored in a directory named:

Frame Manuals

The following table lists the manuals for dual column table model load frames:

Model number	Manual number
34TM-5 (5 kN)	M10-17319-EN
34TM-10 (10 kN)	M10-17320-EN
34TM-30 (30 kN)	M10-17321-EN
34TM-50 (50 kN)	M10-17322-EN
34TM-100 (100 kN)	M10-17681-EN



The manual numbers listed are in English (EN). To find a different language, match the two letter extension on this Operator's Guide to the equivalent language Preinstallation manual, e.g. M10-xxxx-FR for French.

Chapter 2

Risk reduction and safe use

• Residual risks	25
• Collision Mitigation	29
• Ingress Protection	29
• Operator Protection Overview	31

Residual risks

The equipment described in this documentation is designed with features to reduce the risk of injury to an operator. There are, however, always residual risks in the use of this equipment, influenced by:

- the test application
- the design of the test method or procedure
- the jog, return and test speeds used
- the type of specimen being tested
- the size of the specimen being tested
- the design of grips and test fixtures
- the experience of the operator using the equipment

It is our strong recommendation, therefore, that you carry out your own risk assessment for your particular equipment setup and testing application.

Each of the following sections describes a specific hazard zone of the testing system and lists the most common risks for testing using this equipment. Use the information in the following sections, together with the instructions in the remainder of this manual, to conduct your own risk assessment.

Rapid crosshead motion

Warning



Crush hazard to fingers or hands.

This hazard relates to grips and fixtures coming together as a result of rapid crosshead motion, crushing hands or fingers.

For example, an operator inadvertently commands the system to jog or return while their hands are in test area. This may also happen if the operator, in an attempt to be more efficient, reaches in to remove broken specimen pieces while simultaneously returning the crosshead to zero displacement.

Recommendations

In all situations:

- Set up test methods so that operators do not need to have their hands in the space between fixtures while the crosshead is moving.
- Use the Operator Protection feature in Bluehill® software. This uses a reduced jog speed (default ≤ 600 mm/min) during set up and you can set a lower jog speed if your risk assessment requires it.
- Set appropriate travel limits every time you change the grips and adjust the crosshead.

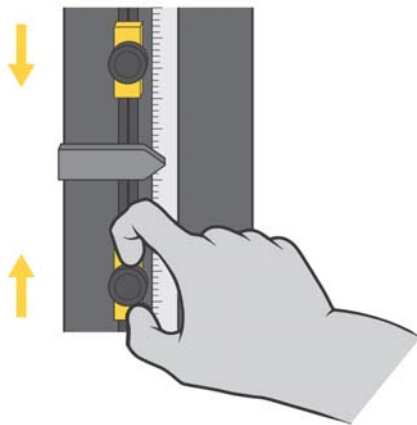

In addition, if the gap between grips and fixtures is less than 50 mm:

- Use a specimen insertion tool and other appropriate equipment and practices to keep fingers out of the space between the fixtures.

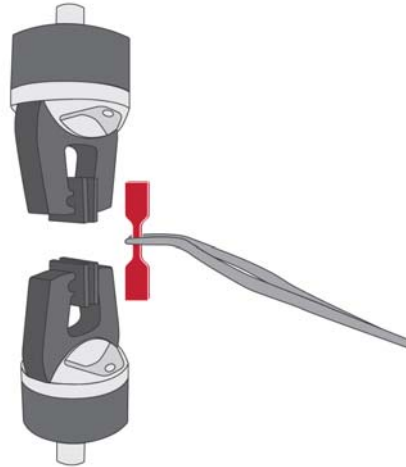

In addition, if the gap between grips and fixtures is less than 25 mm:

- Use a specimen insertion tool to keep fingers out of the space between the fixtures.
- Use an interlocked shield to limit or disallow motion when the shield door is open. When the space is less than 25mm, the crush hazard is very significant, so this is the best option.



Pinching fingers between grip jaw faces

Warning



Pinch hazard to fingers.

This hazard relates to grip jaws closing quickly, pinching fingers.

Recommendations

In the documentation supplied with the grips, read and follow the safety recommendations for installing a specimen.

Refer to the manual addendum (M10-17666-EN) supplied with this manual for more details about the pneumatic grip air kit.

Refer to the manual supplied with the grip pump or other accessory for more details.

Impact of debris from breaking specimens

Warning



Hazard from flying debris.

This hazard relates to brittle or composite specimens that can explode when they break.

Recommendations

For less dangerous debris (specimen dust or fibers, for example):

- Use personal protection equipment (for example safety glasses).



For more dangerous projectile debris (brittle composite specimens, for example):

- Use an interlocked shield.



Collision Mitigation

The 3400 and 6800 Series systems are equipped with the Collision Mitigation feature to help reduce accidental equipment and specimen damage. Collision Mitigation enables the system to continually monitor force during jog and return operations, and will automatically stop the crosshead movement if an unexpected force is detected.

- When paired with the system's matching capacity load cell, Collision Mitigation can protect the system from colliding with rigid surfaces at speeds up to 600 mm/min.
- Collision Mitigation is intended to mitigate damage to the equipment.
- Collision Mitigation is not safety rated, nor safety intended.

Ingress Protection

To comply with relevant safety and machinery design standards, all aspects of the testing system have been designed to meet an ingress protection rating of at least IP 2X. The testing system is designed for indoor use only, away from wet areas.

The first digit of the ingress protection rating (IP 2_) signifies protection against ingress by solid objects. The number "2" indicates that the design prevents any solid object larger than 12.0 mm from contacting any hazardous internal components (e.g. moving parts, electrical hazards) when all covers and guards are in place.

The second digit of the ingress protection rating (IP_X) signifies protection against ingress by liquids. The letter “X” indicates that ingress protection against liquid is not required to be specified for this application. The testing system is protected only against hazards caused by the incidental spillage of liquids.

Note that in many cases, pragmatic improvements against solid and liquid ingress have been implemented in the design to improve durability and longevity of the testing system.

Solid particle ingress

Solid particles and other debris, particularly conductive or abrasive dust (e.g. metal scale, carbon-based composite fibers) may cause damage to the testing system if allowed to accumulate. If your testing application generates debris, follow these special precautions:

- Clean the testing system and adjacent areas frequently with a vacuum or soft brush to prevent any accumulation of debris.
- As part of periodic maintenance, contact Instron[®] Service to inspect the inside of the testing system for accumulation of debris, and clean it if necessary.
- Clean all outer surfaces thoroughly before performing any service. This prevents debris from falling onto the internal components of the testing system.

Liquid ingress

Any liquid spill onto the testing system may cause equipment damage. Incidental liquid spills will not pose a hazard to the operator if properly addressed.

Take particular care when using any accessory that could spill liquid onto the testing system (e.g. condensation from an environmental chamber, BioBath, or hydraulic accessories).

Instron[®] sells a variety of accessories, such as drip trays, that can be used to reduce the impact of spilled liquids on your testing system.

If a liquid spill occurs:

1. Discontinue testing immediately and turn off the power to the equipment. Unplug the power cord (if applicable).
2. Clean up as much spilled liquid as possible on the outside of the equipment. Be sure to check underneath rubber mats (if present) and any installed accessories.

3. If you have reason to believe that liquid entered the testing system, contact Instron[®] Service.
 - a The service engineer will remove the covers of the equipment and clean up all traces of spilled liquid.
 - b Any components damaged by liquid may need to be replaced.
 - c The service engineer will perform an operational check to verify proper function of safety systems.

Warning



Continuing to operate a testing system after liquid has entered the testing system may pose a hazard to the operator and lead to additional equipment damage.

4. Resume testing only after the liquid spill has been properly cleaned up. If the testing system exhibits any faults or unexpected behavior, discontinue testing immediately and contact Instron[®] Service.

Operator Protection Overview

The majority of hazards for operating materials testing systems are associated with:

- rapid movement of the crosshead causing crush injuries
- rapid closing of pneumatic grips causing pinch injuries

Operator Protection in Bluehill[®] provides a mechanism that lets you limit crosshead jog speed and reduce grip closing pressure while you are setting up a test.

The default conditions during test set up are:

- crosshead jog speed reduced to a maximum of 600 mm/min, and can be set lower if your risk assessment requires it
- grip closing pressure reduced to a default of 15 psi, and can be set lower if your risk assessment requires it.

Refer to the manual addendum (M10-17666-EN) supplied with this manual for more details about the pneumatic grip air kit.

Operator Protection lets an Administrator configure the testing system to be consistent with the risk assessment for that system.

Access to the controls for Operator Protection is password protected. If you have Administrator rights you can modify Operator Protection in the Admin tab in Bluehill®.

Refer to “[Operator Protection](#)” on page [59](#) for more details.

Chapter 3

Installation

• Level the load frame	33
• Power supply compatibility	34
• System components	38
• First time startup	50

Level the load frame

Level the load frame immediately after you position it for installation. This prevents the base from rocking and provides a level test surface for more accurate results.

Refer to [Figure 3](#) on page 33 and follow the procedure.

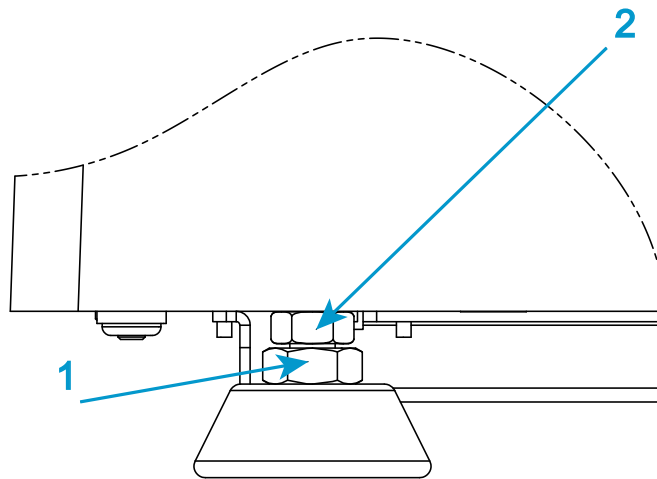

Figure 3. Adjust the leveling feet

You need the following equipment (supplied in the ancillary parts kit unless specified otherwise):

- Spirit level (not supplied)
- 19mm combination wrench (part no. P632-484)
- 16mm thin open-ended wrench (part no. P632-482)

Caution

Make sure that the full weight of the frame is bearing down on the feet. If it is not, you will not be able to adjust the feet.

1. Place a spirit level on the center of the base beam.
2. Use the 19mm wrench to loosen the lock nut (1) on each leveling foot.
3. Use the 16mm thin open-ended wrench to turn the level adjuster nut (2) on each foot while you monitor the spirit level reading.

Warning



As you make adjustments, make sure that no more than 12 mm (0.5 in) of thread is exposed.

If you expose more than 12 mm (0.5 in) of thread, there is a risk that the threaded adapter can separate from the foot.

4. Rotate the spirit level 90 degrees to verify that the load frame is level side to side and front to back.
5. When the machine is level, use the 16mm thin open-ended wrench to hold the level adjuster nut (2) while using the 19mm wrench to tighten the lock nut (1) on each foot.

Power supply compatibility

The first step in the installation is to verify that the voltage and electrical plug are compatible with the location's power supply.

The power cord set and plug is based on the country to which the frame was shipped and is compatible with the electrical requirements for that country.

Warning



Frames may overheat or suffer damage if connected to a power supply greater than 15% above the configured voltage.

Caution

Frames may not be able to run at rated speeds if connected to a power supply more than 5% below the configured voltage.

Before proceeding with installation, verify the following:

- The machine's voltage is compatible with the main power supply of your facility. Refer to "[Determine the voltage setting](#)" on page 36.
- The machine's power cable can reach the electrical power supply with some slack in the cable.
- The plug is compatible with the electrical power outlet.

If your power source is not the voltage originally specified on your purchase order, you can follow the instructions in "[Change the voltage setting](#)" on page 36 to change the voltage. Ensure that you use the appropriate electrical plug when changing voltages.

Warning



Hazard - Do not remove covers to any component of your system, unless it is specified in a procedure.

There are dangerous voltages and rotating machinery inside the machine that may cause bodily injury or damage to equipment.

Warning



Electrical hazard - to ensure safety and Electromagnetic Compatibility (EMC) the facility's receptacle must be a 3-wire grounded receptacle. The ground must be a low impedance earth ground in accordance with national and/or local regulations.

The frame operates from a single-phase, two-wire grounded power source that applies 240 volts rms or less between the supply conductors or between the ungrounded supply conductor and earth ground.

The connector on the power cable must be compatible with the power source. If the power cable supplied with your system does not fit your power source outlet, add a male plug to the cable that is compatible with the voltage. Observe the CEE wire color code as follows:

- Brown - high (live)
- Light blue - low (neutral)

- Green and yellow - earth (ground)

Set the input voltage

The load frame voltage is factory set according to the voltage that was specified at the time of purchase.

Use the following procedures only if the facility power source does not match the frame voltage setting. This situation may arise if the system is moved to another location with a different voltage rating from the factory setting on the frame.

Determine the voltage setting

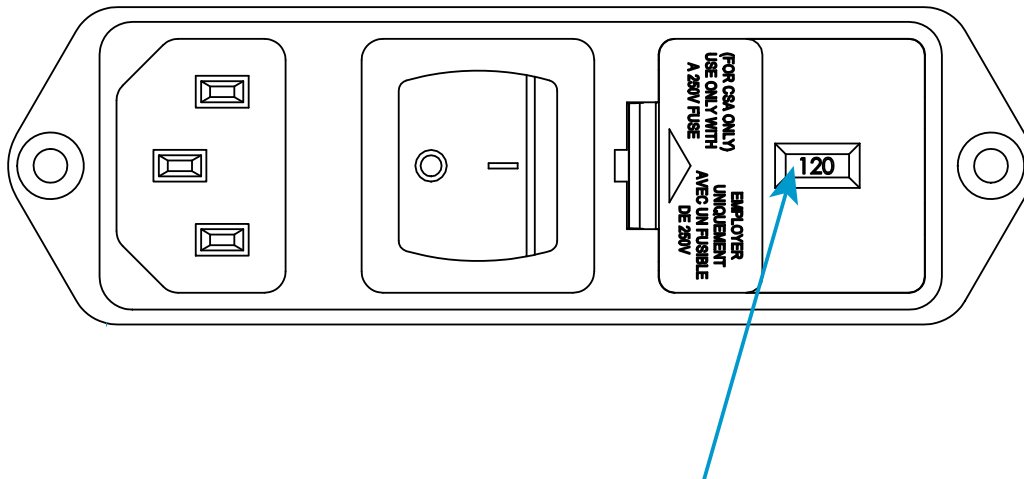

Figure 4. Power input connector with voltage setting

1. Locate the power input connector on the rear of the testing machine base.
2. Inspect the power input connector and refer to [Figure 4](#) on page [36](#). The indicated voltage in [Figure 4](#) is 120V.

Change the voltage setting

Use the following procedure only if the facility power source does not match the frame voltage setting. This situation may arise if the system is moved to another location with a different voltage from the factory setting on the frame.

You will need the following equipment (not supplied):

- Small flat-head screwdriver or probe
- Long-nose pliers

Warning



Electrical hazard - shut off the main power switch and disconnect the power to the frame before changing the power setting. There are dangerous voltage levels inside the fuse holder.

Warning



Hazard - Do not remove covers to any component of your system, unless it is specified in a procedure.

There are dangerous voltages and rotating machinery inside the machine that may cause bodily injury or damage to equipment.

1. Ensure that the power switch is in the Off (0) position and disconnect the power cable from the power source. Verify that no LEDs are illuminated on the frame control panel.
2. Insert a small flat-head screwdriver into the slot indicated in [Figure 5](#) on page 37 and pry out the fuse holder.

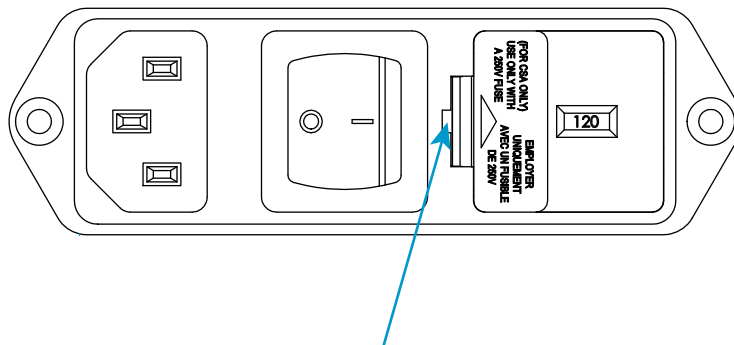

Figure 5. Prying out the fuse holder

3. Remove the fuse holder (1) from the power input connector.
4. Using long-nose pliers, remove the voltage selector unit (see [Figure 6](#) on page 38).

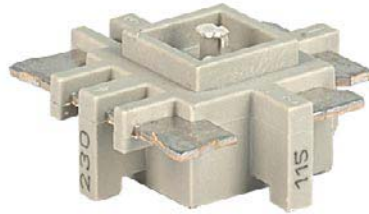

Figure 6. Voltage selector unit

5. Re-insert the voltage selector unit into the connector so that the required voltage faces front.
6. If necessary, change the fuse holder. Refer to [“Replace a Fuse”](#) on page 129 for instructions on replacing a fuse.
7. Re-install the fuse holder into the connector. Ensure that the indicator pin now indicates the correct input voltage. See [Figure 4](#) on page 36 for reference.
8. Reconnect the power cable to mains power and turn on the system. Verify that the white **DISABLED** indicator on the frame control panel illuminates.
9. Before you carry out any testing, perform the procedure described in [“First time startup”](#) on page 50.

System components

Instron[®] Service installs your testing system. These diagrams and instructions are provided as a reference if you need to move the system after the initial installation.

Dual column table model load frame

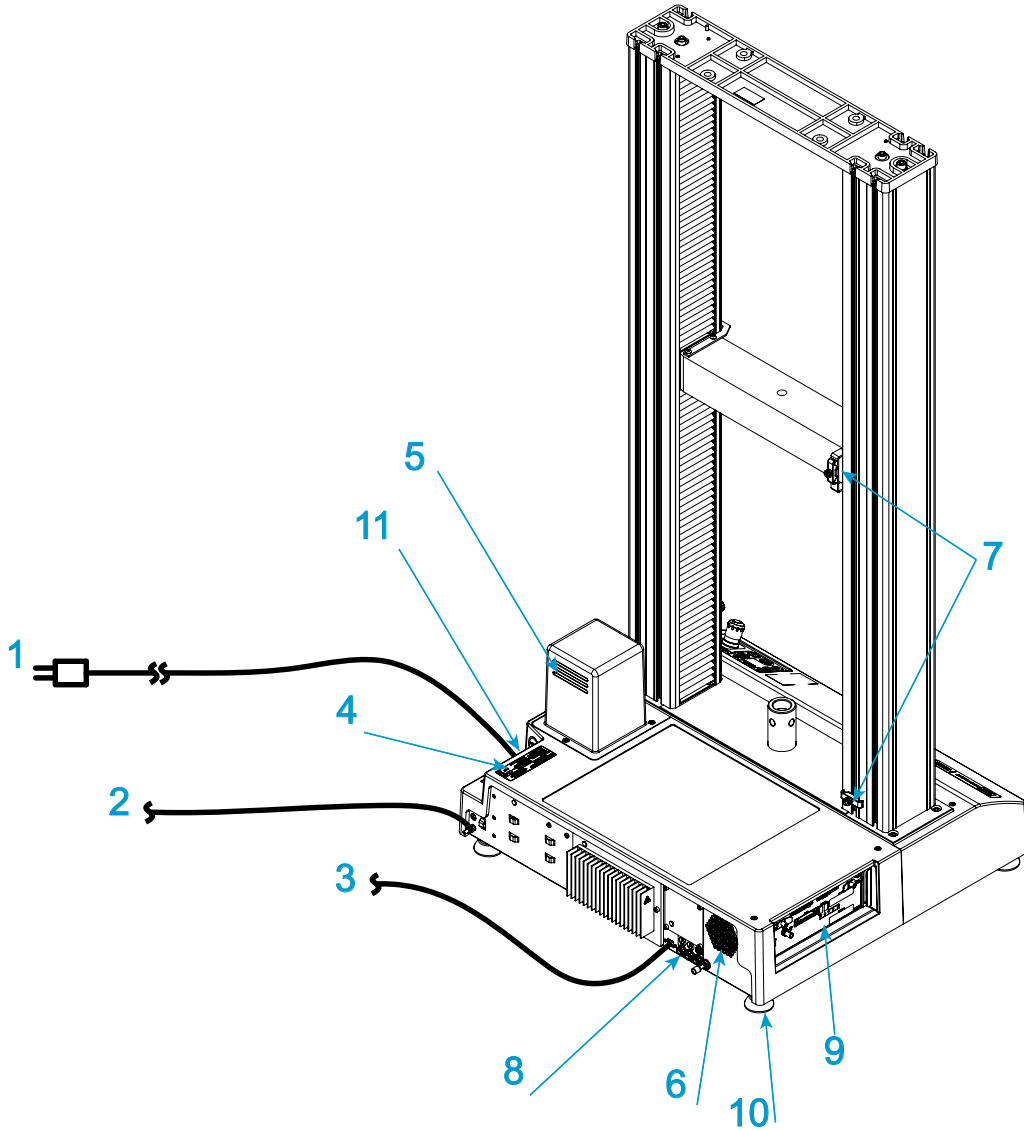

Figure 7. Frame connections

Legend for Figure 7

Label	Component	More detail
1	Mains cable and plug	

Label	Component	More detail
2	Ground connection (when required)	“Ground connection detail” on page 44
3	To Bluehill® Operator Dashboard or separate computer (not shown in Figure 7)	
4	System ID label	
5 and 6	Exhaust vents	Leave at least 152 mm (6 in) of space behind the frame to allow for ventilation and periodic access.
7	Cable clip	Use T-nut, cable clips, cable tie hooks and loops to secure load cell cables and pneumatic grip connections
8	Rear panel	“Rear panel connections detail” on page 41
9	Controller panel	“Controller connections detail” on page 43
10	Adjustable feet	“Level the load frame” on page 33
11	Power inlet connection, power switch, fuses and voltage selector	“Power supply compatibility” on page 34

Rear panel connections detail

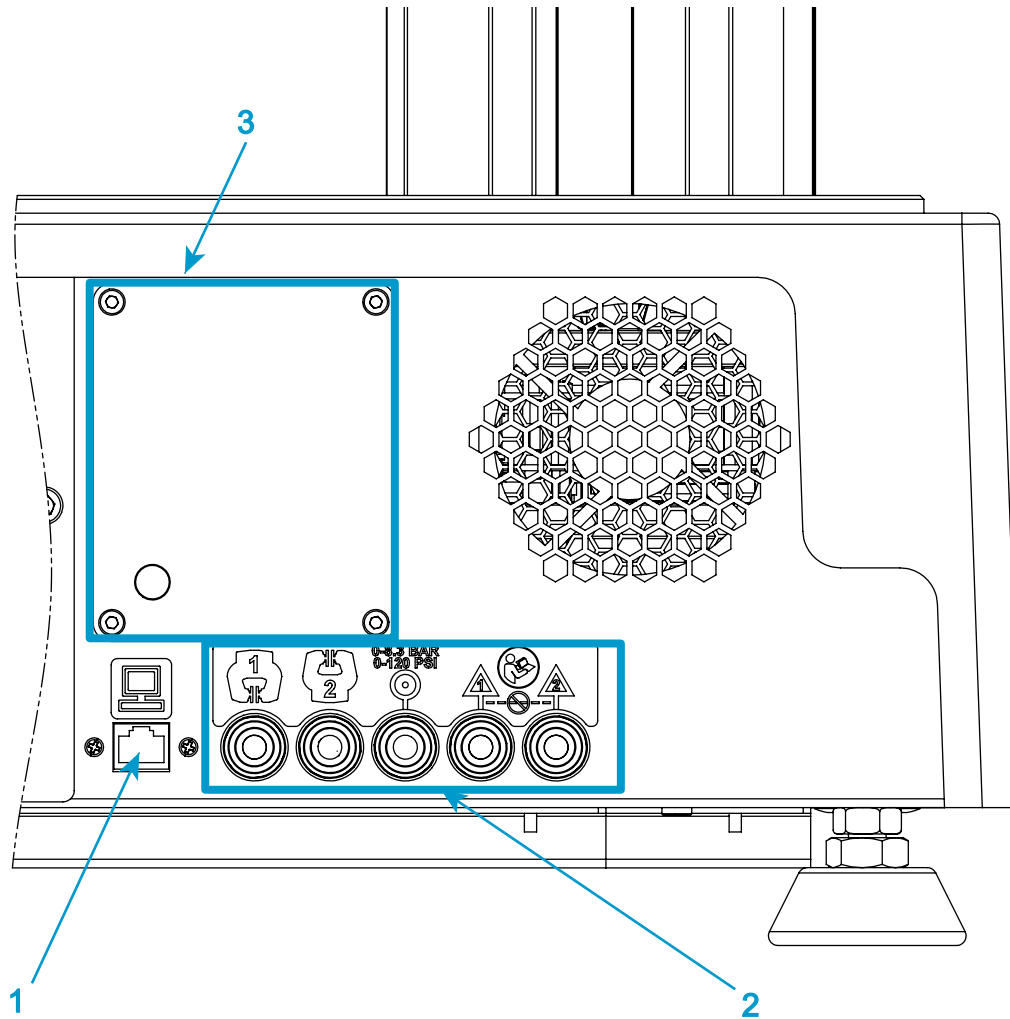

Figure 8. Rear panel connections detail

Legend for [Figure 8](#)

Label	Component	More detail
1	Ethernet (to Bluehill [®] Operator Dashboard) or separate computer	

Label	Component	More detail
2	Pneumatic grip air kit connections	Refer to the manual addendum (M10-17666-EN) supplied with this manual for more details about the pneumatic grip air kit.
3	Various optional accessory connections, e.g. hydraulic grip pump, interlocked shields	Refer to the manual supplied with the grip pump or other accessory for more details.

Warning



Whenever you remove powered grips from the load string, always disconnect them from the power source.

Any grips connected to the system remain operational, even if they are not mounted in the load string.

Controller connections detail

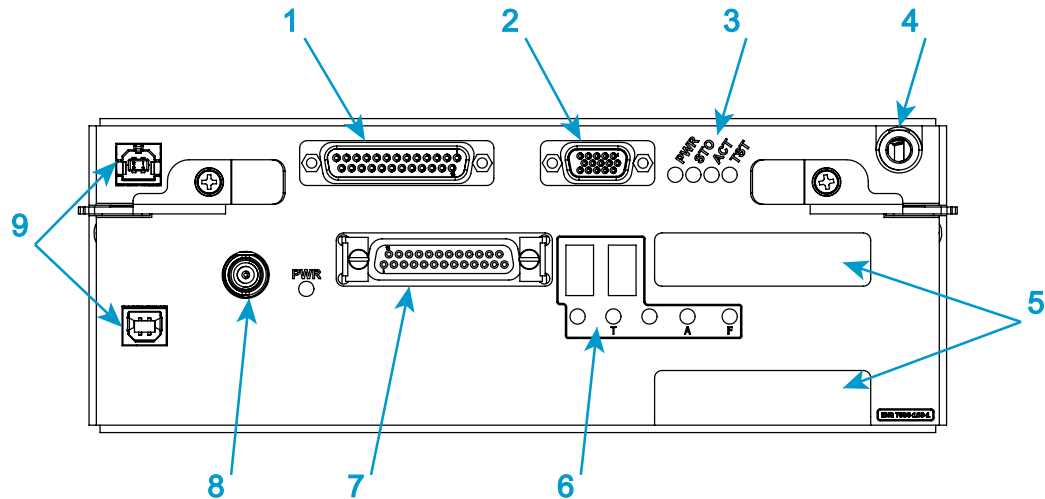

Figure 9. Controller connections detail

Legend for Figure 9

Label	Component	More detail
1	Encoder connector	Connects to various accessories, including AVE2 and AutoX extensometers
2	Grip control connector (may be labeled FOOT SWITCH on some systems)	Connects to the grip control device. This may be a foot switch or a handset depending on the grips in use.
3	Status indicators	
4	PIP jack	
5	Strain connectors	Optional
6	Status indicators	
7	Force connector	Connects to load cell
8	Sync connector	CAUTION: ESD Sensitive See Caution details below table.
9	Service connectors	For use by Instron® Service only

Caution

ESD Sensitive - Do not remove the rubber cover on the SYNC connector unless it is specified in a procedure.



The electronics are susceptible to electrostatic discharge which may affect system performance when the SYNC connector is exposed or ungrounded.

Ground connection detail

If the electrical supply is not grounded, you must use this functional ground connection to connect the frame to a suitable ground in the building.

This connection can also be used in certain cases when auxiliary equipment, such as an automatic extensometer or a monitoring device, requires grounding for functional reasons or for EMC compliance. Any instructions for connection to this ground will be in the documentation for the accessory.

Refer to [Figure 10](#) on page [45](#) for connection details.

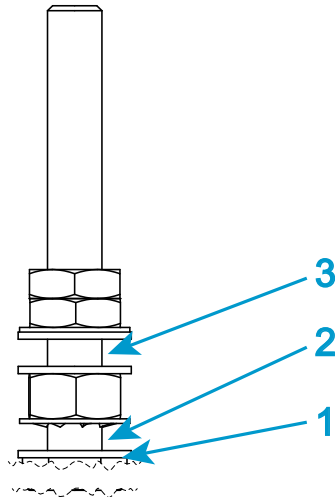

Figure 10. Ground connection detail

Legend for [Figure 10](#)

Label	Description
1	Sheet metal
2	Connect ground cable for frame here
3	Connect ground cable for any accessories here

Connect the system components

Instron[®] Service installs your testing system. These instructions are provided as a reference if you need to move the system after the initial installation.

This procedure describes the connections for the basic components of the system. If you purchased additional accessories for your system, you need to refer to the documentation for those accessories for proper installation.

Warnings



Electrical hazard - Do not connect power cables when the power is on. Turn the power off to avoid hazardous voltages and component damage.



Hazard - Do not remove covers to any component of your system, unless it is specified in a procedure.

There are dangerous voltages and rotating machinery inside the machine that may cause bodily injury or damage to equipment.

Caution

ESD Sensitive - Do not remove the rubber cover on the SYNC connector unless it is specified in a procedure.



The electronics are susceptible to electrostatic discharge which may affect system performance when the **SYNC** connector is exposed or ungrounded.

1. Ensure that the power switch is set to Off (O) and the mains power cable to the machine is disconnected.
2. Connect the load cell cable to the **FORCE** connection on the controller (see [“Controller connections detail”](#) on page 43).
3. If using any type of powered grips, refer to the documentation provided with the grips for details.

For example:

- pneumatic grips with the integrated air kit - refer to the manual addendum (M10-17666-EN) supplied with this manual for more details about the pneumatic grip air kit
 - hydraulic grips - refer to the manual supplied with the grip pump for more details about hydraulic grips
4. Use the cable clips on the column to secure the load cell cable and pneumatic grip connections (see [“Dual column table model load frame”](#) on page 39).
 5. Instron[®] systems provide an option to measure strain. If your system is equipped to measure strain, connect the extensometer to the **STRAIN 1** connection on the controller (see [“Controller connections detail”](#) on page 43). Always use **STRAIN 1** as the primary connection for strain. **STRAIN 2** is an available option that you can use to connect another extensometer or other strain device to the system.

Caution

The connectors labeled SERVICE are for the use of Instron[®] Service only. Never connect any equipment to any of the SERVICE connectors.

6. If the frame or any accessories require a ground (earth) connection, make the connections (refer to [“Ground connection detail”](#) on page 44).
7. Connect the Ethernet connection on the Bluehill[®] Operator Dashboard to the Ethernet connection on the rear panel (see [“Rear panel connections detail”](#) on page 41).
8. Verify the following:
 - a. The machine’s voltage is compatible with the main power supply of your facility. Refer to [“Determine the voltage setting”](#) on page 36. If it is not, refer to [“Change the voltage setting”](#) on page 36.
 - b. The plug is compatible with the electrical power outlet.

Warning



Frames may overheat or suffer damage if connected to a power supply greater than 15% above the configured voltage.

Caution

Frames may not be able to run at rated speeds if connected to a power supply more than 10% below the configured voltage.

9. Connect the mains power cable to the IEC connector on the rear of the machine and to the electrical power supply (see [“Dual column table model load frame”](#) on page 39).
10. Connect the mains power cable on the Bluehill[®] Operator Dashboard to the electrical power supply.

The system is now ready to be turned on. Refer to [“First time startup”](#) on page 50.

Bluehill[®] Operator Dashboard

The Bluehill[®] Operator Dashboard provides a touch-friendly interface for controlling your testing machine using Bluehill[®] software.

Adjustment and connection

Instron[®] Service will install the Bluehill[®] Operator Dashboard on your system.

1. You can adjust the height of the Bluehill[®] Operator Dashboard for the comfort of different operators. Loosen the lock (1 in [Figure 11](#) on page 48) and slide the arm mounting (2 in [Figure 11](#) on page 48) to the desired height. Re-tighten the lock.

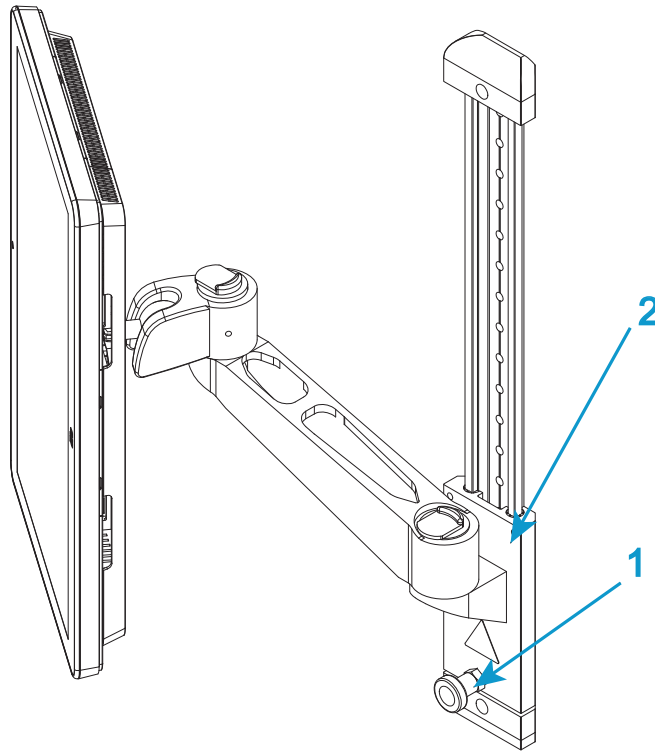

Figure 11. Height adjustment

2. Connect the Ethernet connector on the rear of the Bluehill[®] Operator Dashboard to the Ethernet connector on the rear panel of the testing machine.
3. Connect the mains power cable to the electrical power supply.

Disconnection and moving

If you need to move the testing system you must disconnect and remove the Bluehill[®] Operator Dashboard as follows:

1. Ensure that the power switch is set to Off and the mains power cable is disconnected.

2. Disconnect all cables that connect to or from the Bluehill[®] Operator Dashboard.

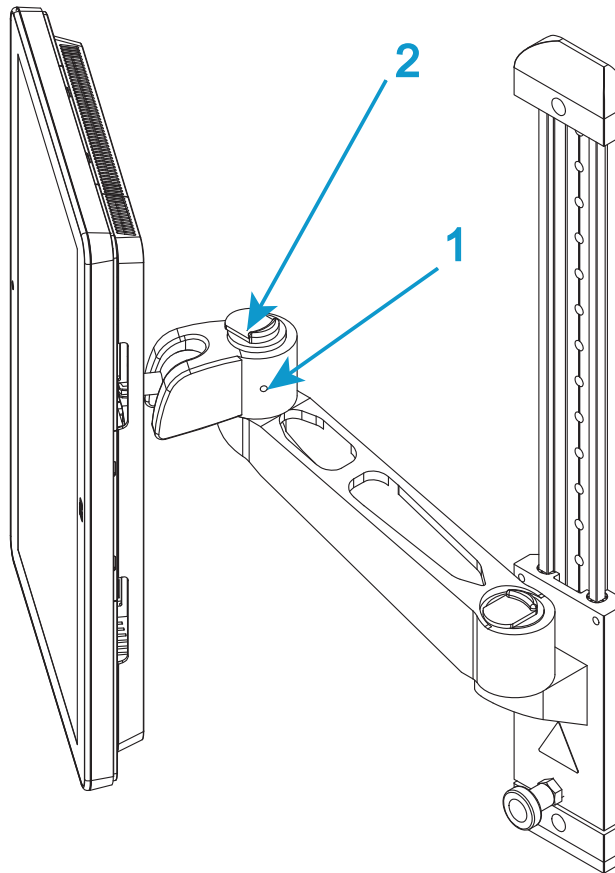

Figure 12. Mounting arm

3. If necessary, loosen the set screw on the side of the “elbow” on the mounting arm (1 in [Figure 12](#) on page 49).
4. Operate the release mechanism on top of the “elbow” (2 in [Figure 12](#) on page 49) and lift the Bluehill[®] Operator Dashboard clear of the mounting arm ([Figure 13](#) on page 50).

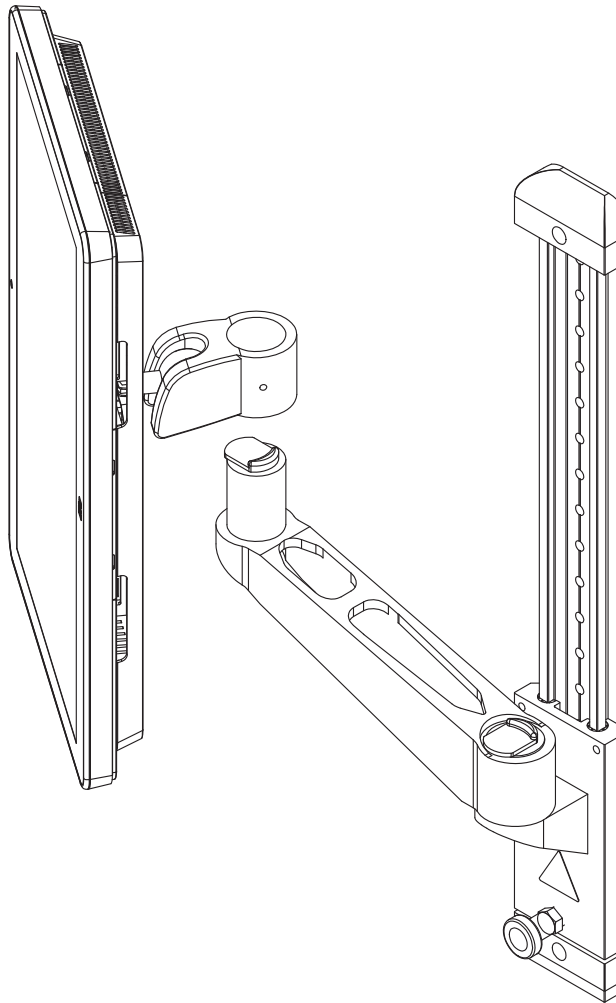

Figure 13. Lift to remove

5. Place the Bluehill® Operator Dashboard face down on a soft material to avoid scratching the screen.

First time startup

When the testing system is installed, you need to configure Bluehill® to communicate with the testing hardware.

1. Ensure that all cables are properly installed and securely connected.

2. Turn the power switch on the machine to the On (1) position.
The white LED above the **DISABLED** indicator flashes.
3. Turn on the power to the Bluehill[®] Operator Dashboard and any other accessories that make up the testing system.
4. Start the Bluehill[®] software.
The first time the software is started, the configuration wizard runs.
5. Follow the instructions in the configuration wizard. The keycode for the software is printed on the media supplied. Steps include:
 - select the controller type and frame model
 - enter the system ID (located on a label on the rear of the frame)
 - enter the Ethernet address (located on a label on the controller panel)
 - enter any additional information, e.g. service contract number
 - select any additional accessories that are installed

If you need to change any of these settings, when you purchase an additional accessory for example, go to the Admin tab in the software.

Chapter 4

Function of controls

- Power input connector 53
- Emergency Stop button..... 54
- Frame Control Panel 55
- Bluehill® software..... 57
- Operator Protection 59
- Bluehill® Operator Dashboard 68

Before you start the system, make sure you familiarize yourself with the following controls:

Power input connector

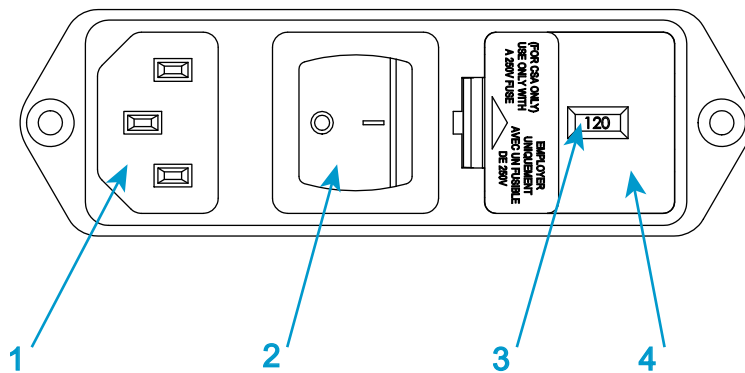

Figure 14. Power input connector

Legend for [Figure 14](#)

Label	Component
1	IEC inlet connector

Label	Component
2	Power switch
3	Selected voltage
4	Fuse carrier and voltage selector access

The power input connector, shown in [Figure 14](#) on page [53](#), performs the following functions:

- connects the load frame to the electrical power supply
- contains the **ON/OFF** switch
- holds the power fuse
- controls the voltage setting. The voltage setting can be changed if necessary, refer to [“Power supply compatibility”](#) on page [34](#).

Refer to [Figure 2](#) on page [17](#) to see the location of the power input connector on your load frame.

Emergency Stop button



Figure 15. Emergency Stop button

The Emergency Stop button is a large, round, red button on the testing system. Press this button to stop the test as soon as possible when a condition develops that:

- could affect the safety of anyone operating the system
- could damage the specimen, load frame, or test fixtures

Warning



If you are using an integrated air kit with a foot switch to control a set of pneumatic grips, be aware that pressing the Emergency Stop button to disable the frame will also deactivate the grips, causing them to open.

With an integrated air kit, any action that disables the frame will also open the grips.

Warning



If you are using hydraulic grips, be aware that pressing the Emergency Stop button to disable the frame will lock the grips in their current position, prohibiting any further motion.

Frame Control Panel

All the controls and indicators for the testing system are on the frame control panel:



Figure 16. Frame Control Panel

Legend for [Figure 16](#)

Label	Description
1	<p>JOG buttons</p> <p>When in SET UP mode, the jog speed is restricted to 600 mm/min or less.</p> <p>When in CAUTION or TESTING mode, the jog speed is unrestricted, i.e. any speed up to the maximum speed for the frame.</p>
2	<p>STOP button</p> <p>Stops crosshead motion, e.g. during jogging, testing, or returning to zero.</p> <p>If you need to disable the frame, press and hold the STOP button for 2 seconds.</p>
3	<p>Mode indicators - different color LEDs that indicate the current mode of the frame.</p> <ul style="list-style-type: none"> • DISABLED (white) • SET UP (blue) • CAUTION (yellow) • TESTING (red)
4	<p>RETURN button - returns the crosshead to zero displacement.</p> <p>Return speed is set in Bluehill[®] software and can be any value up to the maximum speed for the frame.</p> <p>The button is only available after the frame has transitioned to CAUTION mode.</p> <p>When you press this button, the frame runs in TESTING mode until the return is completed.</p>
5	<p>START TEST button - press the button to start a test. Bluehill[®] software must be in the Test screen before you can start a test.</p> <ul style="list-style-type: none"> • The button is only available after the frame has transitioned to CAUTION mode. • When you press this button, the frame runs in TESTING mode until the test is completed or you initiate another action.
6	<p>UNLOCK button - switches the frame between the following modes:</p> <ul style="list-style-type: none"> • DISABLED to SET UP, i.e. enable the frame • SET UP to CAUTION, e.g. prepare to start a test
7	<p>EMERGENCY STOP button - press this button to disable the frame from any mode when a hazardous situation exists. Refer to "Emergency Stop button" on page 54.</p>

The white LEDs above the **UNLOCK**, **TEST** and **RETURN** buttons indicate availability. In [Figure 16](#), the unlock button is available.

Bluehill® software

The software controls:

- setting test parameters
- collecting and analyzing test data

Refer to the Bluehill® online help and reference for more details.

Home Screen

Bluehill® software opens at the Home screen, with the following components:

- Console area at the top and bottom of the screen. Provides important information about the system. Always visible and available from any screen.
- Buttons to access other parts of the software - creating test methods, running tests, analyzing data, producing reports.

Buttons

Table 4. Buttons on the Home screen

Button	Function
Test	Perform tests on specimens. The software displays a sequence of screens where you: <ol style="list-style-type: none"> 1 choose a test method from which to load test parameters. 2 perform tests. 3 name the sample and select a location to store the test data.
Method	Create, edit and save test method files.
Analysis (optional)	Modify an existing sample or replay a sample with parameters from a different test method.
Admin	Change the configuration of the testing system.

Table 4. Buttons on the Home screen (Continued)

Button	Function
Logout	Log out the current user and let a new user log in to the software. When you log out you do not exit the program. This button is hidden if Security is not enabled.
Instron[®] Connect	Uses an Internet connection to check the status of the system, including verification status of transducers. Checks for software updates. You can also use this connection to contact Instron [®] Service for assistance and upload files to Instron [®] Service for diagnosis.
Help	Open the online help.
Exit	Exit the program.

Console area

The console area provides important information during testing and is also where you can edit system wide settings.

At the top of the screen:

- Live displays track values of parameters that you choose
- System button opens the System details dialog where you can view system information, view the event logs, and change settings including:



- set up the load frame and any connected transducers
- set up live displays
- set up soft keys
- set up the test area, specimen protect, jog rate, return rate and collision mitigation
- enable features on powered grips

At the bottom of the screen:

- soft keys that you have set up in the soft keys screen appear here

Status Bar

The status bar appears at the bottom of every screen and provides status information for:

- Security - the name of the currently logged in user or a statement that security is off.
- Machine - is the software connected to a testing machine or running in No machine mode.
- Test type - e.g. tension, compression, metals.
- Sample - the name of the current sample file that is open, if any.
- Method - the name of the current method file that is open, if any.
- Report - the name of the current report template that is open, if any.
- Progress messages - various messages indicating progress, for example “Opening”, “Closing” and “Generating”.

Operator Protection





Operator Protection in Bluehill[®] provides a mechanism that lets you limit crosshead jog speed and reduce grip closing pressure while you are setting up a test.

Operator Protection lets an Administrator configure the testing system to be consistent with the risk assessment for that system.

Access to the controls for Operator Protection is password protected. If you have Administrator rights you can modify Operator Protection in the Admin tab in Bluehill[®].

Operating Modes

Bluehill[®] displays the current system mode corresponding to the four LEDs on the control panel:

DISABLED (white)	SET UP (blue)	CAUTION (yellow)	TESTING (red)
			

Disabled

Bluehill® displays gray border with white text, **Frame is disabled**.

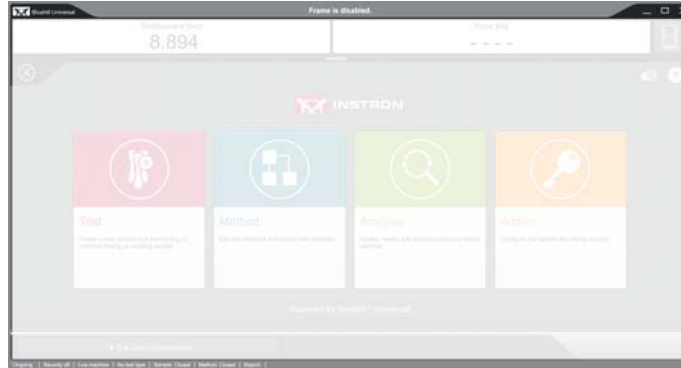

DISABLED (white) LED illuminates on the frame control panel.

This is the default state of the frame upon start up after the software is opened. If the frame is not connected to the software, the LED flashes.

When the frame is disabled:

- crosshead cannot move
- powered grips cannot operate

The frame disables when:

- Emergency stop button is pressed
- A frame fault occurs
- You press and hold the **STOP** button for 2 seconds.

When the frame transitions from any other mode to disabled, any pneumatic grips connected to the integrated air kit will open automatically.

To proceed to **SET UP** mode, you press the **UNLOCK** button.

Set Up

Bluehill® displays blue border with white text, **Ready to set up**.

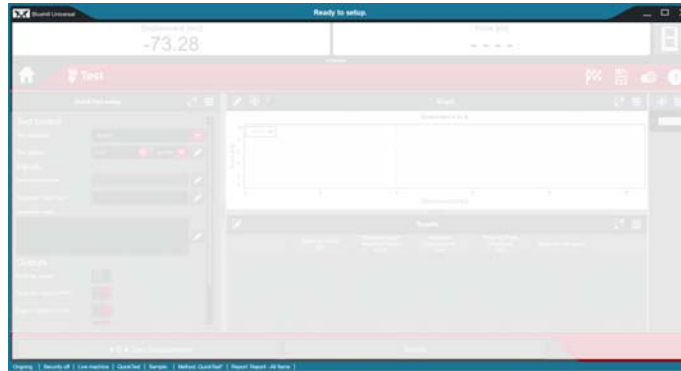

SET UP (blue) LED illuminates on the frame control panel.

This is a restricted state of the frame.



The indicator LED flashes blue whenever the crosshead is moving, e.g. jogging.

When the frame is in set up mode:

- crosshead can jog at the operator protect jog speed (no greater than 600 mm/min)
- pneumatic grips can close at the initial grip pressure (default value of 15 psi)

The frame returns to set up mode when:

- the test is paused (e.g. during extensometer removal)
- after a test is complete
- after a return is complete
- when an interlocked shield is opened

To proceed to **CAUTION** mode, you press the **UNLOCK** button.

Caution

Bluehill[®] displays yellow border with white text, **Ready to test**.

Yellow warning message, **Keep clear of test area**, disappears after a few seconds.

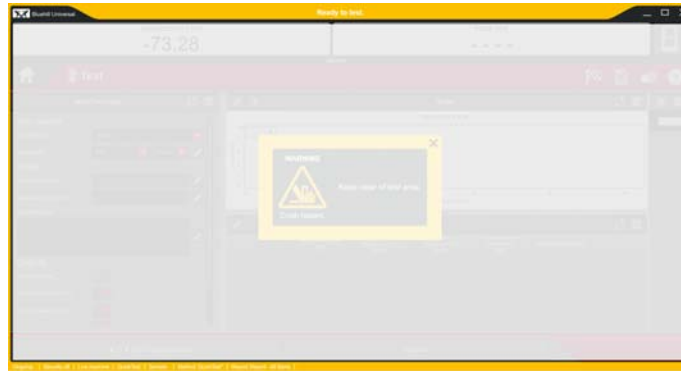

CAUTION (yellow) LED illuminates on the frame control panel.

This is an unrestricted state of the frame.



The indicator LED flashes yellow whenever the crosshead is moving, e.g. responding to the software specimen protect setting.

When the frame is in caution mode:

- pneumatic grips, previously closed at initial grip pressure in the set up state, clamp at full test pressure
- the frame returns to set up mode if a test is not started within 2 seconds (unless a debris shield with interlocks is present and closed)

To start the test, you press the **START TEST** button.

To return the crosshead after completing a test, you press the **RETURN** button.

Testing

Bluehill® displays a red border with white text, **Test in progress**. The border flashes while the crosshead is moving.

Red warning message, **Keep clear of test area**, disappears after a few seconds.

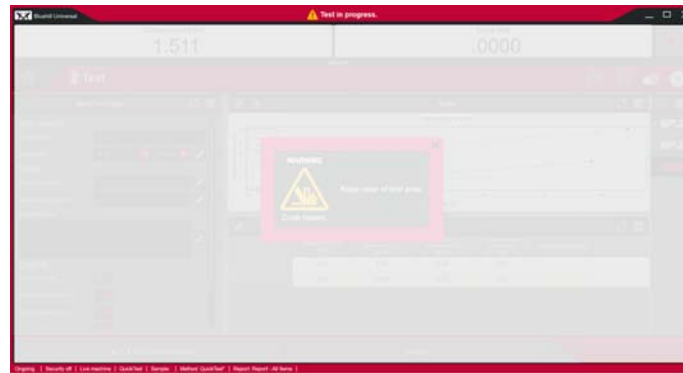

TESTING (red) LED illuminates on the frame control panel and flashes while the crosshead is moving.

This is an unrestricted state of the frame.

When the frame is in testing mode:

- frame is currently running a test
- frame is currently returning to zero displacement after a test

The frame also enters this mode during high-speed jogging, which can be initiated by pressing and holding the **UNLOCK** button while simultaneously pressing one of the **JOG** buttons. Once the jog has started, you can release the **UNLOCK** button so long as you maintain pressure on the **JOG** button. Crosshead speed ramps up gradually to the maximum speed of the frame.

Move between modes

The following table shows how the controls on the frame control panel move the system between modes to set up and run a test.

Table 5. Move between modes



	Initial condition	Action	Result
1	DISABLED (white) 	Press 	SET UP (blue) 

Table 5. Move between modes (Continued)















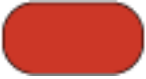

	Initial condition	Action	Result
2	<p>System remains in set up mode until you make a change. During this time you can:</p> <ul style="list-style-type: none"> • move the crosshead at the restricted speed set up in the Admin tab, up to a maximum of 600 mm/min • operate pneumatic grips at the initial pressure set up in the Admin tab, up to a maximum of 15 psi <p>When the specimen is installed and Bluehill® is displaying the Test screen, you can move on.</p>		
3	<p>SET UP (blue)</p> 	<p>Press</p> 	<p>CAUTION (yellow)</p>  <p>Pneumatic grips clamp to full pressure.</p>
4	<p>CAUTION (yellow)</p> 	<p>Press (within 2 secs)</p> 	<p>TESTING (red)</p> 
5	<p>TESTING (red)</p> 	<p>Test runs to completion.</p>	<p>SET UP (blue)</p> 
6	<p>SET UP (blue)</p> 	<p>Press</p> 	<p>CAUTION (yellow)</p> 

Table 5. Move between modes (Continued)

	Initial condition	Action	Result
7	CAUTION (yellow) 	Press (within 2 secs) 	TESTING (red)  Crosshead returns to zero position at speed set in the software.
8	TESTING (red) 	Crosshead returns to zero position.	SET UP (blue) 

Additional notes:

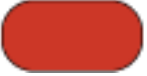
- Once the frame is enabled, the default mode when it is idle is **SET UP** mode with the light above the **UNLOCK** button illuminated. If you want to disable the frame, press and hold the **STOP** button for 2 seconds.
- When you enter **CAUTION** mode, and if you are using a footswitch to control the grips, pneumatic grips clamp to full pressure. If you do not press the **START** button within 2 seconds, the frame returns to **SET UP** mode. The grips, however, remain at full pressure until you run a test. If you are using toggle switches on the grips to control them, the grips are at full pressure only during **TESTING** mode.

Typical test flow

“[Move between modes](#)” on page 63 describes each of the test controls and how they are used to move between testing modes.







For a step-by-step description of a typical test flow using these controls, refer to “[Testing a sample](#)” on page 103. This section contains two procedures, one for systems using an interlock and one for systems without an interlock.

Jog at High Speed

Under normal conditions, in **SET UP** mode, jog speed is limited to 600 mm/min or less. There may be situations, such as moving the crosshead into position at the start of a testing session, where this low speed is inconvenient.

Jogging at high speed involves more risk so the process involves pressing both the **UNLOCK** and **JOG** buttons at the same time, as follows:

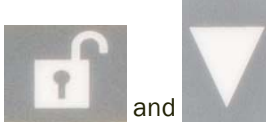
Table 6. High speed jog

Initial condition	Action	Result
SET UP (blue) 	Press  and together	TESTING (red)  Crosshead moves up, ramping up to the maximum speed set in the software.
SET UP (blue) 	Press  and together	TESTING (red)  Crosshead moves down, ramping up to the maximum speed set in the software.

Additional notes:

- Although you must press the **UNLOCK** and **JOG** buttons together to start the jog at full speed, you can release the **UNLOCK** button once the crosshead starts to move. The crosshead ramps up to full speed and continues to move while you are pressing the **JOG** button.
- You would typically use this functionality when initially setting up test fixtures and bringing the crosshead to the correct position to install specimens. Thereafter, you can use the **RETURN** button to bring the crosshead back to the zero displacement position.

Operator Protection Controls

If you have Administrator rights, you can make changes to the Operator Protection settings, via **Admin > Frame > Operator Protection**.

For more details on the operation of these software controls, refer to the Bluehill® online help and reference.

Operator Protection options define the restrictions on the system when it is in **SET UP** mode.

Control	Description
Jog rate	Sets the restricted speed of the crosshead when the system is in SET UP mode. Default setting is 600 mm/min, which is also the maximum permitted. If the maximum speed of the crosshead is less than 600 mm/min, then the restricted speed is limited to the maximum speed of the frame.
Initial grip air pressure	Sets the maximum grip pressure allowed when the system is in SET UP mode. Allows the operator to close the grips on the specimen with sufficient pressure to hold the specimen in place but reduces the risk of injury from pinching.
Override point of control	Default is disabled, which means that the primary point of control for the system is at the load frame. The operator must use the buttons on the frame to start a test or position the crosshead. When this option is enabled, the system can be configured to use the software to initiate these actions.
Override point of control - Start test and return	Default is Frame Controls , i.e. start test and return using the buttons on the frame. Only choose Remote if you are using an interlock accessory. The interlock automatically transitions the system to CAUTION mode when the interlock is closed. If there is no interlock, you must press the UNLOCK button to transition to CAUTION mode.
Pneumatic grips	Enables and disables pneumatic grips connected to the testing system with the integrated air kit.

Control	Description
<p>Grip control (when pneumatic grips are enabled)</p>	<p>Default is Footswitch. You close both grips using the integrated air kit and foot switch.</p> <p>Toggle switch lets you use the toggle switches on the grips with the integrated air kit. The footswitch is disabled when you choose this.</p> <p>Remote lets you control the grips via a software program operating through the API.</p> <p>Upper footswitch/lower remote applies only if your test method includes pretension. Upper grip closes with the foot switch and the lower grip closes automatically after the specified load threshold is achieved.</p>
<p>Behavior when the interlock is tripped</p>	<p>If the testing system includes an accessory with an interlock, then Operator Protection defines the behavior of the frame when the interlock is tripped. For example, when an interlocked door is opened and the operator has access to the test area.</p> <p>Disable frame - the frame is disabled when the interlock is tripped. This is the recommended setting as it is the safest.¹</p> <p>Allow limited motion - the frame remains enabled when the interlock is tripped. This allows an operator access to the test area while allowing limited crosshead movement as specified in Operator Protection.</p> <p>Although this option can facilitate installing a specimen or removing an extensometer during a test, it also increases the risk of injury. You should perform a risk assessment before selecting this option.</p>



1. If you choose this option, be aware that the operation of pneumatic grips is also disabled. If you want no crosshead motion when the interlock is tripped but need pneumatic grips to function, select **Allow limited motion** and set **Jog rate** to 0 mm/min.

Bluehill[®] Operator Dashboard

The Bluehill[®] Operator Dashboard provides a touch-friendly interface for controlling your testing machine using Bluehill[®] software.

Basic touch functions

Basic touch screen functions in Bluehill[®]:

- tap a control to select it (equivalent to clicking in non-touch interfaces)
 - to enter text in a field, tap the field and, if the keyboard is not already displayed, tap the keyboard icon to display it
 - to enter numbers in a field, tap the keypad button to the right of the field
 - if there is a task menu associated with part of a screen (accessed via right-click in non-touch interfaces), there will be a Menu button on the screen. Tap it to open the menu.
- 
- if there is a Properties dialog associated with part of a screen, there will be a Properties button on the screen. Tap it to open the dialog.
- 
- enable/disable controls (check boxes in non-touch interfaces) are toggle controls. Tap the control to enable or disable it. Enabled is colored, disabled is gray.

Touchscreen gestures

Gestures supported in Bluehill®:

- graph - pinch to zoom (must also be enabled in the Admin screen)
- test workspace component - if the component is maximized, you can move between components by selecting the appropriate icon in the tool bar below the maximized component
- test workspace setup - when editing test workspace layout, swipe left or right to move between available components
- test workspace specimen selector - swipe up (portrait orientation) or swipe left (landscape orientation) to display a panel that lets you quickly include or exclude a specimen from the sample
- any scrollable screen component - flick up or down, left or right to quickly scroll through the list

Chapter 5

Assemble the load string

• Select a load cell	72
• Before you begin	73
• Install a load cell - 34TM load frames up to 50 kN capacity	74
• Install a load cell - 34TM-100 load frame only	81
• Adapters	91
• Coupling adapters	96
• Select Grips and Fixtures	97
• Preload the load string	99
• Unload the load string	101

The load string consists of all the hardware components between the crosshead and the base of the testing machine. It includes the load cell, grips, the specimen and any adapters that let you connect any of these components together.

Instron[®] Service sets up the testing machine during installation, but you may need to change one or more of these components for different types of testing.



When creating a load string, keep in mind the maximum capacity for all the components making up the load string. The expected test load should not exceed the maximum capacity of any load string components including, but not limited to:

- load frame
- load cell
- adapters
- grips or fixtures

Select a load cell

If you know the approximate tensile or compressive strength of the material that you are testing, use these guidelines to choose a load cell:

- Make sure that the load cell is verified for the range of force that you anticipate for your testing
- If there is a choice between two different load cells because of overlapping ranges:
 - select a higher capacity load cell when you require minimum deflection of the load cell
 - select a lower capacity load cell when you require maximum long term balance or stability

If you don't know the tensile strength of the material, refer to a Properties of Materials handbook to obtain an approximate strength. To calculate the tensile strength in force units for a specimen, use the following equation:

tensile strength x cross-sectional area

For example, for a standard ASTM tensile specimen (0.502 in wide, 0.125 in thick) made with a material of tensile strength 5200 psi (from Materials Handbook) perform the following calculation:

$$5200 \times 0.502 \times 0.125 = 328 \text{ lbf}$$

This produces a recommendation of the 5 kN (1000 lb, 500kg) capacity load cell.

If you cannot determine an approximate value of tensile strength, use the highest capacity load cell rated for the frame. Perform a preliminary test at a very slow speed to obtain the load range required. You can then determine if a lower capacity load cell can provide improved resolution.

[Table 7](#) on page [73](#) lists the load cells that are recommended for use with these frames.

If you have a load cell that is not listed, contact Instron[®] for advice on compatibility and adapters that may be available for your load cell.

Table 7. 2530 Series

Catalog no.	Capacity N (lbf)	Effective length mm (in)	Mechanical fitting	Interface size
2530-5N	5 N (1)	48 (1.89)	2.5 mm clevis pin and 6 mm clevis pin	OOf Of
2530-10N	10 N (2.25)	48 (1.89)	2.5 mm clevis pin and 6 mm clevis pin	OOf Of
2530-50N	50 N (11)	48 (1.89)	2.5 mm clevis pin and 6 mm clevis pin	OOf Of
2530-100N	100 N (22)	48 (1.89)	2.5 mm clevis pin and 6 mm clevis pin	OOf Of
2530-500N	500 N (112)	91 (3.58)	6 mm clevis pin	Of
2530-1KN	1 kN (225)	91 (3.58)	6 mm clevis pin	Of
2530-2KN	2 kN (450)	91 (3.58)	6 mm clevis pin	Of
2530-5KN	5 kN (1125)	101 (3.98)	12.5 mm clevis pin	Df
2530-10KN	10 kN (2250)	122 (4.80)	12.5 mm clevis pin	Df
2530-30KN	30 kN (6750)	148.2 (5.83)	12.5 mm clevis pin	Df
2530-50KN	50 kN (11250)	148.2 (5.83)	12.5 mm clevis pin	Df
2530-100KN	100 kN (22500)	136 (5.4)	12.5 mm clevis pin	Df

Before you begin

Check the following before installing a load cell:

- You have all the parts required for installation. Refer to the appropriate figure for your load cell in [“Install a load cell - 34TM load frames up to 50 kN capacity”](#) on page 74 or [“Install a load cell - 34TM-100 load frame only”](#) on page 81
- Mounting screws are lubricated.
- A torque wrench is available.
- All threads, bores and mating surfaces are clean and free of damage.
- The crosshead is positioned below its travel midpoint so that you can easily and safely access the crosshead.

- The frame is in the disabled state, i.e. the white LED above the **DISABLED** indicator on the frame control panel is illuminated.

Install a load cell - 34TM load frames up to 50 kN capacity

These instructions cover the installation of load cells from 5 N up to 50 kN on the following load frames:

- 34TM-5
- 34TM-10
- 34TM-30
- 34TM-50

For load cell installation on the 34TM-100 frame, refer to [“Install a load cell - 34TM-100 load frame only”](#) on page 81.

Install a 2530 load cell (capacities 5 N through 5 kN)

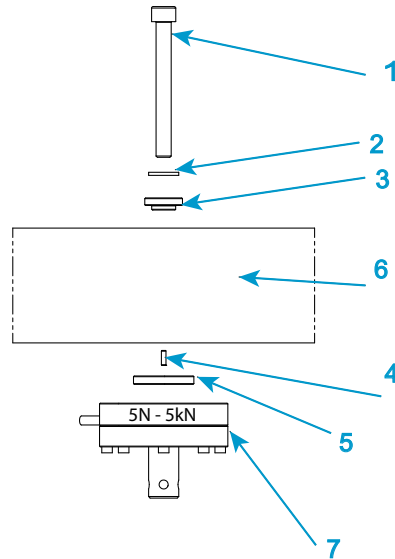

Figure 17. Install a 2530 series load cell - capacities 5 N through 5 kN

Legend for [Figure 17](#)

Label	Component	Part number
1 (34TM-5 and 34TM-10)	Screw, M10 x 90	201V62
1 (34TM-30 and 34TM-50)	Screw, M10 x 140	71-63-1169
2 (34TM-5 and 34TM-10)	Not required	
2 (34TM-30 and 34TM-50)	Two M10 load washers	610J9
3	M10 spacer	T604-90
4	Load cell anti-rotation pin	705K84
5	Locating ring	T1335-1048
6	Crosshead	
7	2530 load cell - 5 N through 5 kN	

1. Refer to [Figure 17](#) on page [75](#) and its associated legend.

Caution

Check items 1 and 2 in the legend carefully. The screw, washer and number of washers required depends on the frame model.

2. Collect together the correct mounting screw, washer, anti-rotation pin and locating ring for your combination of load frame and load cell.
3. Assemble the mounting screw and washer, as shown in the figure.
4. Place the mounting screw and washer assembly into the top of the central bore of the crosshead.
5. Insert the anti-rotation pin into one of the holes on the bottom of the crosshead.



There are four pin holes on the bottom of the crosshead that let you position the load cell either straight on or at an angle.

6. Place the locating ring onto the top surface of the load cell that connects to the crosshead.
7. Place the load cell against the bottom of the crosshead, ensuring that the anti-rotation pin and locating ring fit securely in place against both the crosshead and load cell. Place the cable to the left side of the column.
8. Tighten the mounting screw by hand so that it secures to the load cell underneath the crosshead.
9. Lower the crosshead to a position below the center of the travel range to prevent tipping.

Caution

When applying torque to the mounting screw, prevent the load frame from sliding by holding the crosshead with one hand while applying torque with the other.

10. Use the torque wrench to tighten the mounting screw to 40 N-m (29.5 ft-lb).
11. Connect the load cell cable to the **FORCE** connector on the controller. Ensure that the connector is fully engaged in the socket.
12. Press the load cell cable into the clips on the column cover to prevent it from interfering with your test.
13. Calibrate the load cell (refer to [“Calibrate a transducer”](#) on page 111).
14. Leave the system on for at least 15 minutes to allow the load cell circuitry to stabilize. After this warm-up period, calibrate the load cell again.

Install a 2530-10kN load cell

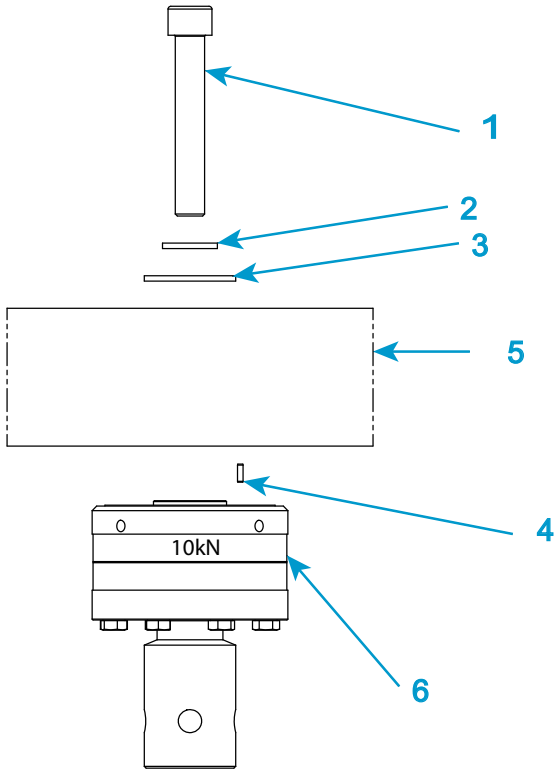

Figure 18. Install a 2530-10kN load cell

Legend for [Figure 18](#)

Label	Component	Part number
1	Screw, M16 x 100	201V85
2	M16 load washer	610J12
3	M17x50x3 mm washer	610K12
4	Load cell anti-rotation pin	705K84
5	Crosshead	
6	2530 load cell - 10 kN	

1. Refer to [Figure 18](#) on page 77 and its associated legend.

2. Collect together the correct mounting screw, washer and anti-rotation pins for your combination of load frame and load cell.
3. Assemble the mounting screw and washer, as shown in the figure.
4. Place the mounting screw and washer assembly into the top of the central bore of the crosshead.
5. Insert the anti-rotation pin into one of the holes on the bottom of the crosshead.



There are four pin holes on the bottom of the crosshead that let you position the load cell either straight on or at an angle.

6. Place the load cell against the bottom of the crosshead, ensuring that the anti-rotation pin and locating ring fit securely in place against both the crosshead and load cell. Place the cable to the left side of the column.
7. Tighten the mounting screw by hand so that it secures to the load cell underneath the crosshead.
8. Lower the crosshead to a position below the center of the travel range to prevent tipping.

Caution

When applying torque to the mounting screw, prevent the load frame from sliding by holding the crosshead with one hand while applying torque with the other.

9. Use the torque wrench to tighten the mounting screw to 60 N-m (44.3 ft-lb).
10. Connect the load cell cable to the **FORCE** connector on the controller. Ensure that the connector is fully engaged in the socket.
11. Press the load cell cable into the clips on the column cover to prevent it from interfering with your test.
12. Calibrate the load cell (refer to [“Calibrate a transducer”](#) on page 111).
13. Leave the system on for at least 15 minutes to allow the load cell circuitry to stabilize. After this warm-up period, calibrate the load cell again.

Install a 2530 load cell (capacities 30kN and 50kN)

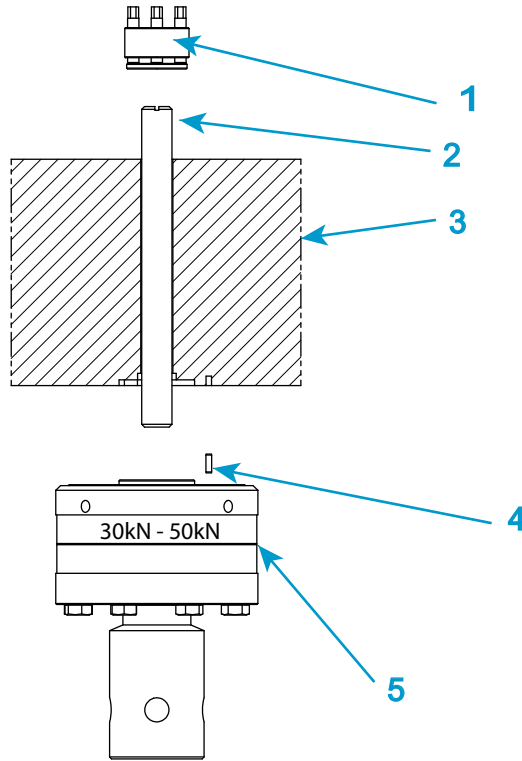

Figure 19. Install a 2530 series load cell - capacities 30kN and 50kN

Legend for [Figure 19](#)

Label	Component	Part number
1	Mechanical tensioner, M16 x 2 thread with matching washer	52-2-82
2	Threaded rod, M16 x 170 mm long	T620-978
3	Crosshead	
4	Load cell anti-rotation pin	705K84
5	2530 load cell - 30 kN through 50 kN	

1. Refer to [Figure 19](#) on page 79 and its associated legend.

2. Prepare the mechanical tensioner and its matching washer by backing off the four set screws so that they are flush with the bottom of the tensioner body. Do NOT remove them.
3. Screw one end of the threaded rod into the top of the load cell, ensuring that it is fully engaged. Use a flat-head screwdriver if necessary.
4. Insert the anti-rotation pin into one of the holes on the bottom of the crosshead.



There are four pin holes on the bottom of the crosshead that let you position the load cell either straight on or at an angle.

5. From underneath the crosshead, insert the threaded rod and loadcell assembly into the hole in the center of the crosshead.
6. Place the load cell against the bottom of the crosshead, ensuring that the anti-rotation pin and locating ring fit securely in place against both the crosshead and load cell. Place the cable to the left side of the column.
7. Thread the mechanical tensioner and its matching washer onto the top of the threaded rod.
8. Tighten the mounting assembly by hand so that it secures the load cell underneath the crosshead.

Caution

Make sure that the tensioner assembly is in contact with the crosshead before tightening any of the set screws on the assembly.

9. Lower the crosshead to a position below the center of the travel range to prevent tipping.
10. Use the torque wrench (80-9-11) with the matching 5 mm hex drive socket (67-4-29) supplied in the mechanical tensioner kit to tighten the four set screws (shown in [Figure 20](#)) on the mechanical tensioner to 14 N-m (10.3 ft-lb) according to the following procedure:

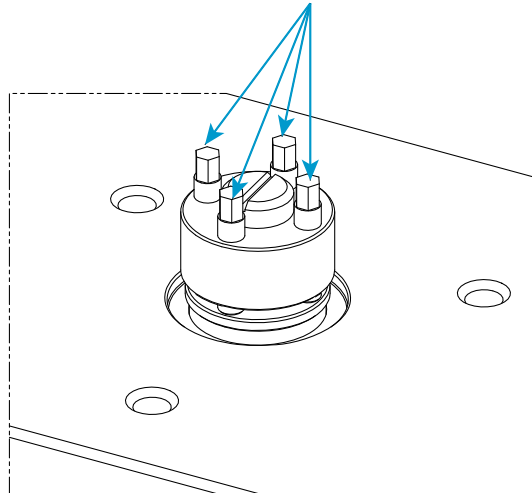

Figure 20. Mechanical tensioner assembly

- a Tighten 2 bolts on opposite sides to 7 N-m (5.1 ft-lb) (50% of the recommended torque).
 - b Tighten the remaining 2 bolts to 14 N-m (10.3 ft-lb) (100% of the recommended torque).
 - c Moving in a circular pattern, re-tighten all bolts to 14 N-m (10.3 ft-lb) (100% of the recommended torque).
11. Connect the load cell cable to the **FORCE** connector on the controller. Ensure that the connector is fully engaged in the socket.
 12. Press the load cell cable into the clips on the column cover to prevent it from interfering with your test.
 13. Calibrate the load cell (refer to “[Calibrate a transducer](#)” on page 111).
 14. Leave the system on for at least 15 minutes to allow the load cell circuitry to stabilize. After this warm-up period, calibrate the load cell again.

Install a load cell - 34TM-100 load frame only

The crosshead configuration on the 34TM-100 load frame is different from other frames in the series.

The following sections describe the hardware required and procedures to install different load cells on this frame.

- “[Install a 2530 load cell \(capacities 5 N through 100 N\)](#)” on page 82

- “Install a 2530 load cell (capacities 500 N through 5 kN)” on page 85
- “Install a 2530 load cell (capacities 10kN through 50kN)” on page 87
- “Install a 2530 100 kN load cell” on page 90

Install a 2530 load cell (capacities 5 N through 100 N)

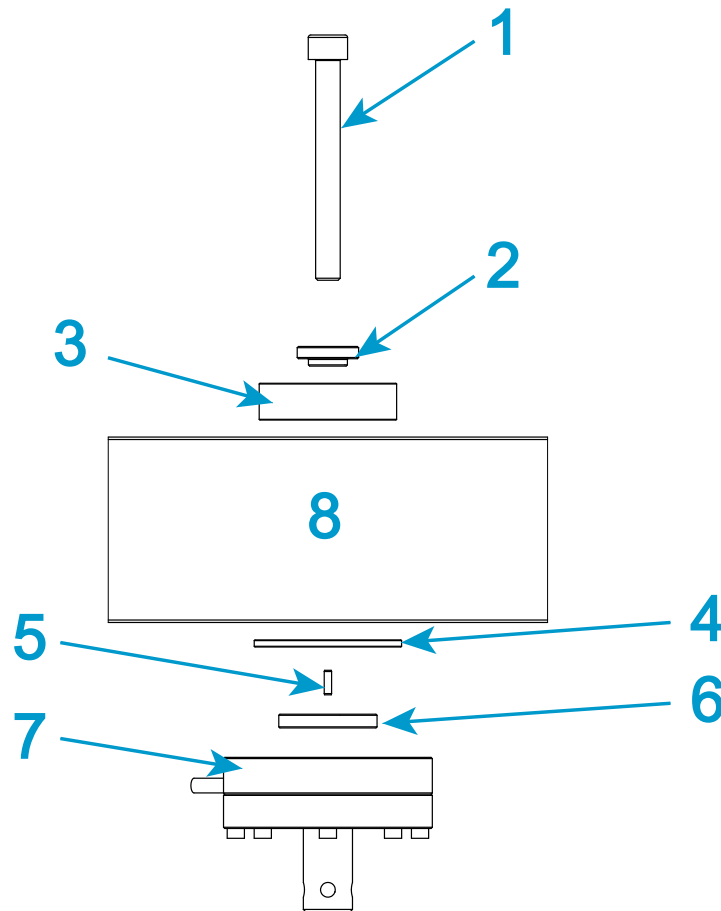

Figure 21. Install a 2530 series load cell - capacities 5 N through 100 N

Legend for Figure 21

Label in Figure 21 on page 82	Component	Part number
1	Screw, M10 x 130	201V633

Label in Figure 21 on page 82	Component	Part number
2	M10 spacer	T604-90
3	Bushing, crosshead center bore	T636-1221
4	Locating ring, 60 mm outer diameter, 40 mm inner diameter	T636-1212
5	Load cell anti-rotation pin	705K84
6	Locating ring	T1335-1048
7	2530 load cell - 5 N through 100 N	
8	Crosshead	

This procedure applies to the 34TM-100 load frame only.

1. Refer to [Figure 21](#) and its associated table and collect together the correct mounting hardware.
2. Assemble the hardware shown above the crosshead in [Figure 21](#) and place it into the top of the central bore of the crosshead.
3. Insert the anti-rotation pin into one of the holes on the bottom of the crosshead.



There are four pin holes on the bottom of the crosshead that let you position the load cell either straight on or at an angle.

4. Place the locating rings onto the top surface of the load cell that connects to the crosshead.
5. Place the load cell against the bottom of the crosshead, ensuring that the anti-rotation pin and locating ring fit securely in place against both the crosshead and load cell. Place the cable to the left side of the column.
6. Tighten the mounting screw by hand so that it secures to the load cell underneath the crosshead.
7. Lower the crosshead to a position below the center of the travel range to prevent tipping.

Caution

When applying torque to the mounting screw, prevent the load frame from sliding by holding the crosshead with one hand while applying torque with the other.

8. Use the torque wrench to tighten the mounting screw to 40 N-m (29.5 ft-lb).
9. Connect the load cell cable to the **FORCE** connector on the controller. Ensure that the connector is fully engaged in the socket.

10. Press the load cell cable into the clips on the column cover to prevent it from interfering with your test.
11. Calibrate the load cell (refer to [“Calibrate a transducer”](#) on page 111).
12. Leave the system on for at least 15 minutes to allow the load cell circuitry to stabilize. After this warm-up period, calibrate the load cell again.

Install a 2530 load cell (capacities 500 N through 5 kN)

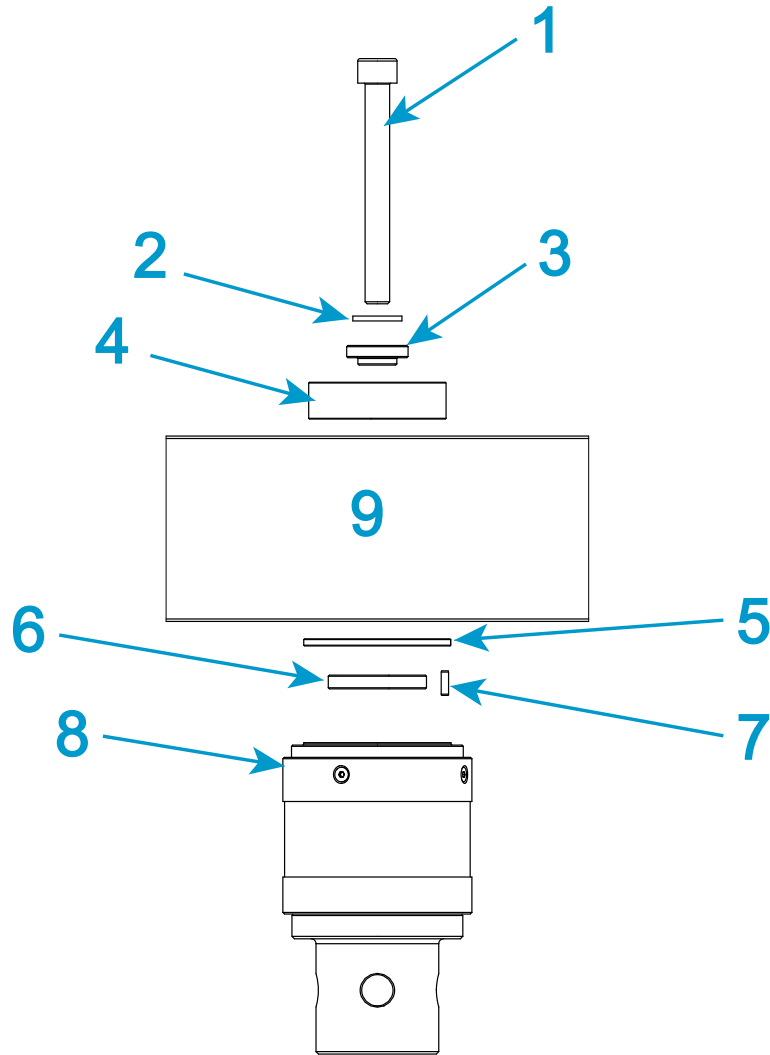

Figure 22. Install a 2530 series load cell - capacities 500 N through 5 kN

Legend for Figure 22

Label in Figure 22 on page 85	Component	Part number
1	Screw, M10 x 140	71-63-1169
2	M10 washer x 2	610J9

Label in Figure 22 on page 85	Component	Part number
3	M10 spacer	T604-90
4	Bushing, crosshead center bore	T636-1221
5	Locating ring, 60 mm outer diameter, 40 mm inner diameter	T636-1212
6	Load cell anti-rotation pin	705K84
7	Locating ring	T1335-1048
8	2530 load cell - 500 N through 5 kN	
9	Crosshead	

This procedure applies to the 34TM-100 load frame only.

1. Refer to [Figure 22](#) and its associated table and collect together the correct mounting hardware.
2. Assemble the hardware shown above the crosshead in [Figure 22](#) and place it into the top of the central bore of the crosshead.
3. Insert the anti-rotation pin into one of the holes on the bottom of the crosshead.



There are four pin holes on the bottom of the crosshead that let you position the load cell either straight on or at an angle.

4. Place the locating rings onto the top surface of the load cell that connects to the crosshead.
5. Place the load cell against the bottom of the crosshead, ensuring that the anti-rotation pin and locating ring fit securely in place against both the crosshead and load cell. Place the cable to the left side of the column.
6. Tighten the mounting screw by hand so that it secures to the load cell underneath the crosshead.
7. Lower the crosshead to a position below the center of the travel range to prevent tipping.

Caution

When applying torque to the mounting screw, prevent the load frame from sliding by holding the crosshead with one hand while applying torque with the other.

8. Use the torque wrench to tighten the mounting screw to 40 N·m (29.5 ft·lb).
9. Connect the load cell cable to the **FORCE** connector on the controller. Ensure that the connector is fully engaged in the socket.

10. Press the load cell cable into the clips on the column cover to prevent it from interfering with your test.
11. Calibrate the load cell (refer to “[Calibrate a transducer](#)” on page 111).
12. Leave the system on for at least 15 minutes to allow the load cell circuitry to stabilize. After this warm-up period, calibrate the load cell again.

Install a 2530 load cell (capacities 10kN through 50kN)

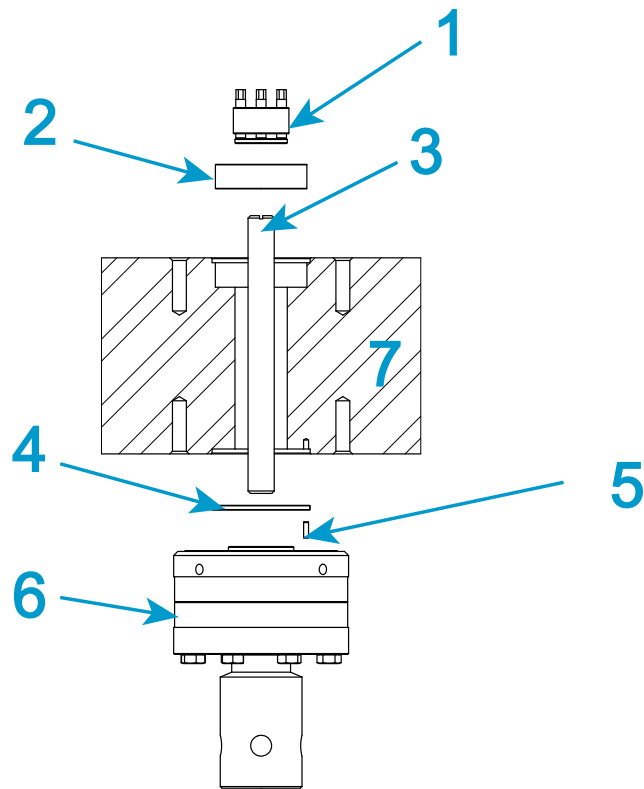

Figure 23. Install a 2530 series load cell - capacities 10kN through 50kN

Legend for [Figure 23](#)

Label	Component	Part number
1	Mechanical tensioner, M16 x 2 thread with matching washer	52-2-82

Label	Component	Part number
2	Bushing, crosshead center bore	T636-1221
3	Threaded rod, M16 x 170 mm long	T620-978
4	Locating ring, 60 mm outer diameter, 40 mm inner diameter	T636-1212
5	Load cell anti-rotation pin	705K84
6	2530 load cell - 10 kN through 50 kN	
7	Crosshead	

This procedure applies to the 34TM-100 load frame only.

1. Prepare the mechanical tensioner and its matching washer by backing off the four set screws so that they are flush with the bottom of the tensioner body. Do NOT remove them.
2. Insert the bushing into the crosshead center bore.

Caution

Failure to include this bushing will cause permanent and irreparable damage to the crosshead and tensioner.

3. Place the locating ring onto the top surface of the load cell that connects to the crosshead.
4. Screw one end of the threaded rod into the top of the load cell, ensuring that it is fully engaged. Use a flat-head screwdriver if necessary.
5. Insert the anti-rotation pin into one of the holes on the bottom of the crosshead.



There are four pin holes on the bottom of the crosshead that let you position the load cell either straight on or at an angle.

6. From underneath the crosshead, insert the threaded rod and loadcell assembly into the hole in the center of the crosshead.
7. Place the load cell against the bottom of the crosshead, ensuring that the anti-rotation pin and locating ring fit securely in place against both the crosshead and load cell. Place the cable to the left side of the column.
8. Thread the mechanical tensioner and its matching washer onto the top of the threaded rod.
9. Tighten the mounting assembly by hand so that it secures the load cell underneath the crosshead.

Caution

Make sure that the tensioner assembly is in contact with the crosshead before tightening any of the set screws on the assembly.

10. Lower the crosshead to a position below the center of the travel range to prevent tipping.
11. Use the torque wrench (80-9-11) with the matching 5 mm hex drive socket (67-4-29) supplied in the mechanical tensioner kit to tighten the four set screws (shown in [Figure 24](#) on page 89) on the mechanical tensioner to 14 N-m (10.3 ft-lb) according to the following procedure:

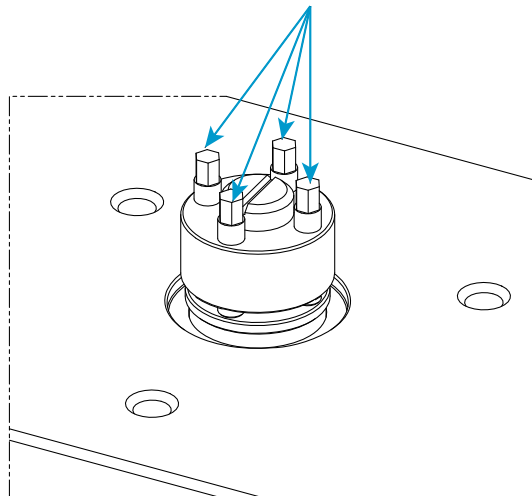

Figure 24. Mechanical tensioner assembly

- a Tighten 2 bolts on opposite sides to 7 N-m (5.1 ft-lb) (50% of the recommended torque).
 - b Tighten the remaining 2 bolts to 14 N-m (10.3 ft-lb) (100% of the recommended torque).
 - c Moving in a circular pattern, re-tighten all bolts to 14 N-m (10.3 ft-lb) (100% of the recommended torque).
12. Connect the load cell cable to the **FORCE** connector on the controller. Ensure that the connector is fully engaged in the socket.
 13. Press the load cell cable into the clips on the column cover to prevent it from interfering with your test.
 14. Calibrate the load cell (refer to [“Calibrate a transducer”](#) on page 111).
 15. Leave the system on for at least 15 minutes to allow the load cell circuitry to stabilize. After this warm-up period, calibrate the load cell again.

Install a 2530 100 kN load cell

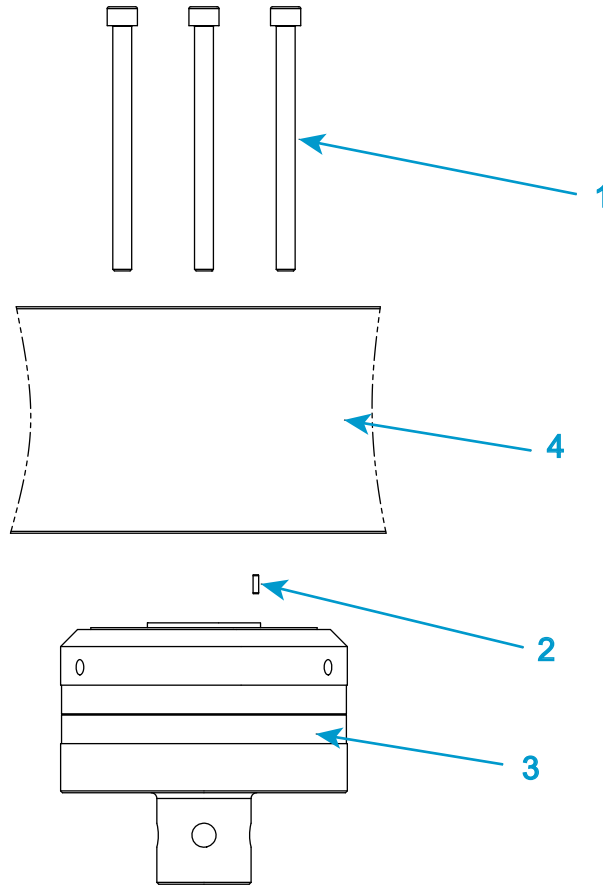

Figure 25. Install a 2530 series 100 kN load cell

Legend for [Figure 25](#) on page 90

Label	Component	Part number
1	6 screws, M10 x 130	201V633
2	Load cell anti-rotation pin	705K84
3	2530 load cell - 100 kN	
4	Crosshead	

1. Insert the anti-rotation pin into one of the holes on the bottom of the crosshead.



There are three pin holes on the bottom of the crosshead. Make sure you use the one that positions the load cell so that the six holes for the mounting screws are aligned correctly with the load cell.

2. Place the load cell against the bottom of the crosshead, ensuring that the anti-rotation pin fits securely in place against both the crosshead and the load cell.
3. Insert the six M10 x 130 mounting screws into the appropriate holes in the crosshead and tighten them by hand to secure the load cell underneath the crosshead.
4. Lower the crosshead to a position below the center of the travel range to prevent tipping.
5. Working in a diagonal pattern, use the torque wrench to tighten the mounting screws to 50 N-m (36.9 ft-lb).
6. Connect the load cell cable to the **FORCE** connector on the controller. Ensure that the connector is fully engaged in the socket.
7. Press the load cell cable into the clips on the column cover to prevent it from interfering with your test.
8. Calibrate the load cell (refer to [“Calibrate a transducer”](#) on page 111).
9. Leave the system on for at least 15 minutes to allow the load cell circuitry to stabilize. After this warm-up period, calibrate the load cell again.

Adapters

Adapters let you connect grips or fixtures to the frame when the interfaces have different connection sizes. There are two types of adapters: base adapters and coupling adapters.

Base adapters

Base adapters let you connect grips and fixtures to the base of the load frame. The load frame is supplied with a Type D base adapter installed. If you need to remove and re-install the base adapter, for example to change the orientation, use the following procedures.

For 34TM frames from 5 kN to 50 kN capacity, refer to:

- [“Remove the base adapter”](#) on page 92
- [“Re-install the base adapter”](#) on page 93

For the 34TM-100 load frame, refer to:

- [“Remove the base adapter - 34TM-100”](#) on page 94
- [“Reinstall the base adapter - 34TM-100”](#) on page 95

Remove the base adapter

1. Remove the compression spring located inside the adapter.
2. Insert a 14 mm hex key into the base adapter, ensuring that it fits into the screw at the base of the adapter.
3. Loosen and remove the screw inside the adapter.
4. Lift the adapter away from the base beam.

Re-install the base adapter

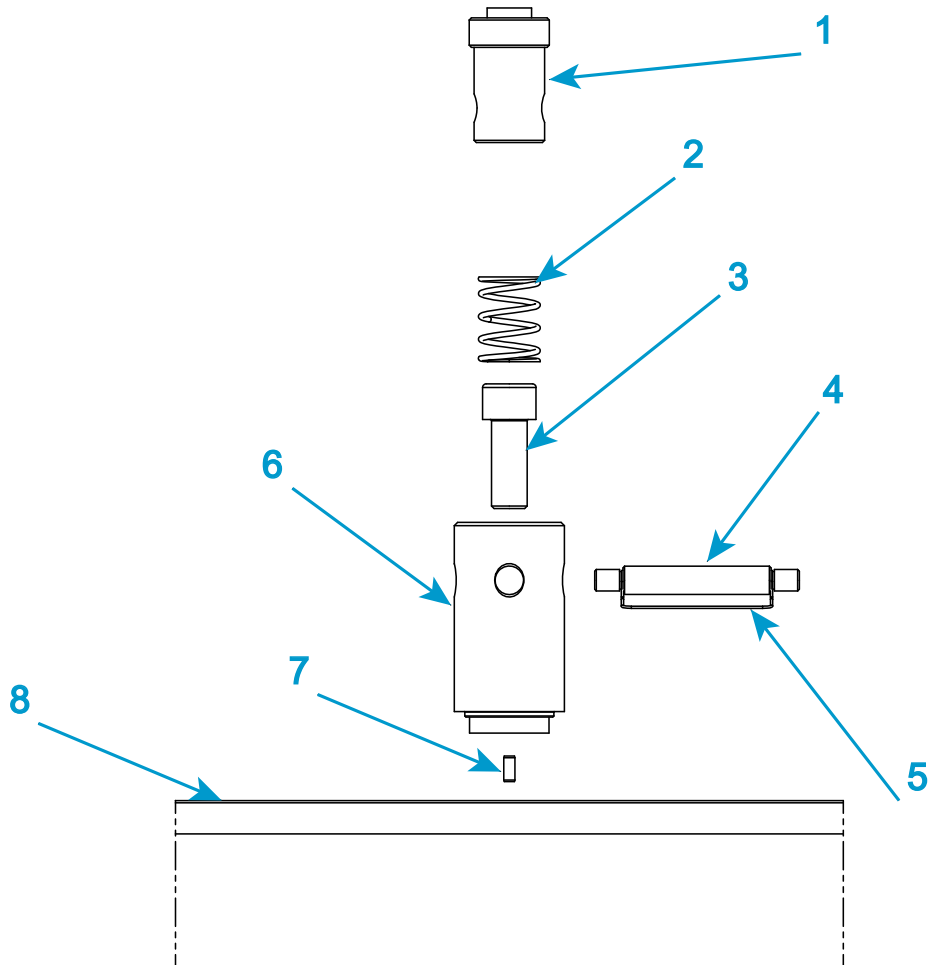

Figure 26. Type D base adapter

Legend for [Figure 26](#)

Label	Component	Part number
1	Grip	
2	Compression spring	66-4-23
3	M16x40 mm screw	
4	Clevis pin	T29-515
5	Clevis pin clip	T1223-1053

Label	Component	Part number
6	Type D base adapter	
7	Load cell anti-rotation pin	705K84
8	Load frame base beam	

1. Insert the adapter into the base beam, noting the orientation of the locating pin on the bottom of the adapter. There are a number of locating pin holes on the base beam to allow for different orientations of the base adapter.
2. Insert a 14 mm hex key into the base adapter, ensuring that it fits into the screw at the base of the adapter.
3. Use the torque wrench to tighten the screw according to the following list:
 - for 34TM-5 and 34TM-10 frame, torque to 60 N-m (44.3 ft-lb)
 - for 34TM-30 frame, torque to 120 N-m (88.5 ft-lb)
 - for 34TM-50 frame, torque to 200 N-m (147.5 ft-lb)
4. Remove the hex key and insert the compression spring.

Remove the base adapter - 34TM-100

1. Remove the compression spring located inside the adapter.
2. Use the 8 mm bit (part no. 80-3-13) to loosen and remove the six M10 screws that secure the adapter to the base beam.
3. Lift the adapter away from the base beam.

Reinstall the base adapter - 34TM-100

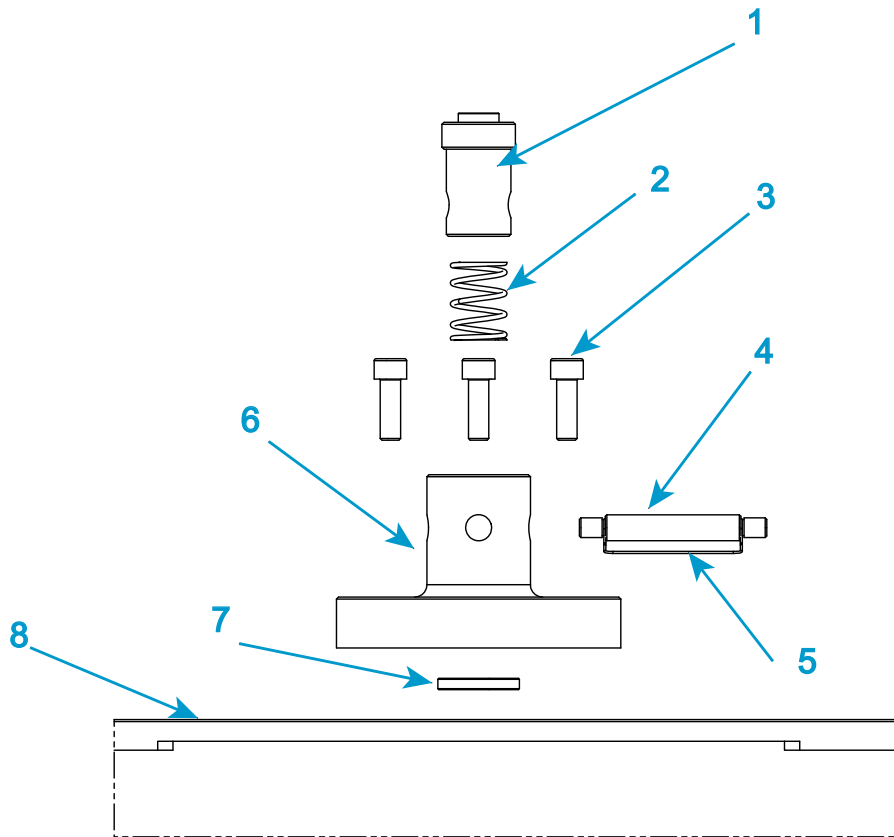

Figure 27. Type D base adapter - 34TM-100

Legend for Figure 27

Label	Component	Part number
1	Grip	
2	Compression spring	66-4-5
3	M10 x 40 mm screw (x6)	
4	Clevis pin	T29-515
5	Clevis pin clip	T1223-1053
6	Type D base adapter	
7	Alignment ring	

Label	Component	Part number
8	Load frame base beam	

1. Place the adapter on the base beam, positioning it over the alignment ring.
2. Use the 8 mm bit (part no. 80-3-13) and the six M10 screws to secure the base adapter to the base beam.
3. Use the torque wrench to tighten the mounting screws to 50 N-m (36.9 ft-lb) working in a diagonal pattern.
4. Insert the compression spring into the center of the base adapter.

Coupling adapters

Coupling adapters let you attach grips and fixtures of different sizes to the load cell and base adapter, providing more options for testing. There are two primary types:

- **For tension testing only:**
Tension coupling adapters, also known as self-aligning coupling adapters, which provide a swivel connection and connect between clevis pin type interfaces. The swivel action allows the grip or fixture to self-align in the direction of the test load, thus minimizing any bending load on the specimen.
- **For tension or compression testing:**
Rigid coupling adapters which also connect between clevis pin type interfaces but use check nuts to provide fixed connections. This type can also have a threaded interface. These couplings are not self-aligning and the load string alignment is dependent on the accuracy of load cell alignment during installation.

When assembling the load string, you may need to use adapters if the load cell interface, or base adapter interface, differs from your grip interface. A coupling adapter creates a secure connection between these two different interfaces.

If your grip or fixture interface is the same size as your load cell interface, then you can connect these directly and you do not need an adapter. If, however, you need the self-aligning feature that the adapter offers, you should use the appropriate self-aligning coupling adapter.

Coupling types are listed from the load cell towards the accessory or from the frame base towards the accessory. For example, if you need to connect a load cell with a Type D (female) connector to a grip with a Type O (male) connector you require a Type Dm to Of adapter.

Select Grips and Fixtures

A set of grips are installed on the system during installation by a service engineer. If your testing requires it, you may need to install a different set to obtain optimum test results.

The selection of grips depends on the material, geometry and strength of the test specimen.

In compression testing, the diameter or area of the anvil is important, in addition to the maximum loading capacity.

For tensile testing:

- Make sure the tensile strength of the specimen does not exceed the maximum loading capacity of the grips.
- Minimize the risk of slippage by:
 - selecting jaw faces with a surface area large enough to cover the tab (for dumbbell-shaped specimens) or as much surface area as possible for parallel-sided specimens.
 - ensuring that the specimen is gripped by at least 75% of the available jaw face length.
 - using serrated jaw faces
- Breaks at the jaw face may be caused by:
 - Screw action grips - you may be using too much force when tightening the grips. Use a torque wrench or switch to pneumatic grips for a consistent force.
 - Powered grips - the pressure may be too high. Drop the pressure, but not to the point where you get slippage.
 - Serrated faces - the serrations are damaging the specimen. Change to faces that have more serrations per inch (less bite) or cover with masking tape or similar material to soften the bite and prevent damage to the specimen.

Insert Jaw Faces into Grips

Different grips use different mechanisms for attaching jaw faces. Refer to the documentation supplied with the grips for more information.

Install grips

Before you begin, check the following:

- There is sufficient space between the load cell and the load frame base to install the grips.
- The crosshead is stationary.
- The frame is in the disabled state, i.e. the white LED above the **DISABLED** indicator on the frame control panel is illuminated.
- The crosshead limit stops on the load frame are set to prevent the upper and lower grips from colliding with each other (refer to “[Set the crosshead limit stops](#)” on page [116](#)).
- The mating surfaces of the grips, load cell and the base adapter are free of dirt or debris.

Refer to [Figure 28](#) on page [99](#) when following this procedure.

1. For the upper grip, insert the adapter on the grip into the female clevis socket (1 in [Figure 28](#)) on the load cell adapter.
2. Align the clevis holes (2 in [Figure 28](#)) and insert the clevis pin (3 in [Figure 28](#)) through the holes.
3. Secure the clevis pin in position with the clevis pin clip (4 in [Figure 28](#)).
4. Repeat steps 1 through 3 to install the lower grip onto the load frame base adapter.
5. When both grips are installed, follow the procedure to preload the load string (refer to “[Preload the load string](#)” on page [99](#)).

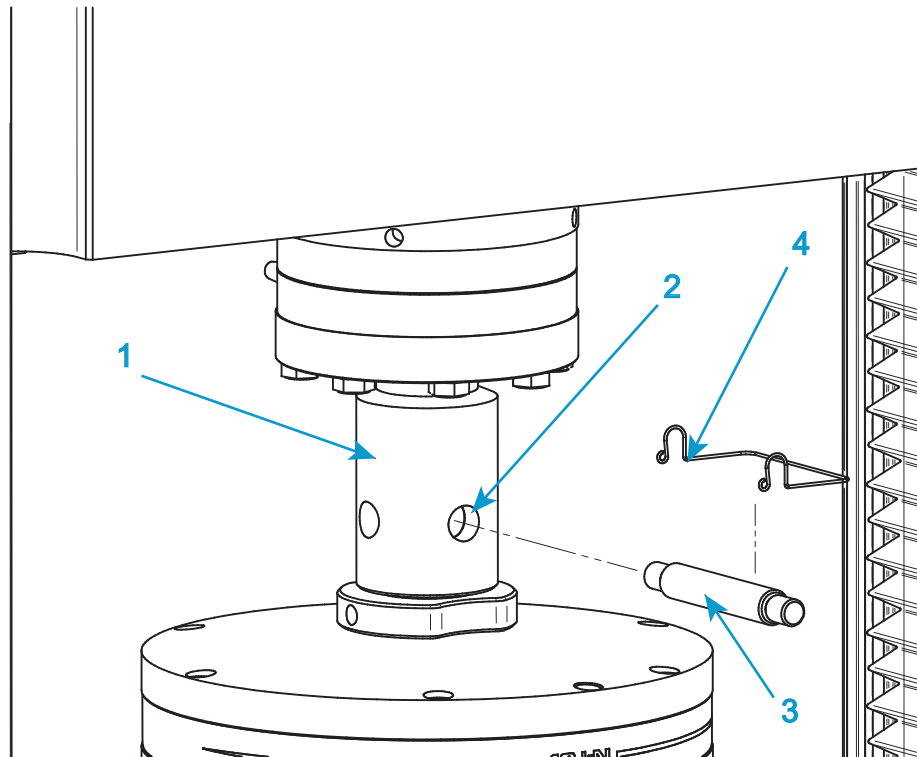

Figure 28. Typical grip installation

Preload the load string

This procedure eliminates backlash and deflections within the load string which can degrade the integrity of test results, especially when testing at high loads. The procedure involves preloading the entire load string and then hand-tightening all the lock nuts on all the grips and couplings. Even when using self-aligning couplings on the upper grip, it is good practice to preload the lower grip.

You will need a rigid specimen that is strong enough to sustain the preload value without breaking. This means a specimen that can sustain a load that is:

- 10% above the expected test load, or
- the maximum load rating of the weakest component of the load string (grips or load cell)

whichever is less. For example, if your grips are rated at 1kN, the load cell at 2kN and your expected test load is 500N then you should preload to at least 550N but not more than 1kN.

Before inserting the specimen ensure that:

- The grips and couplings are installed but the lock nuts are not tightened.
 - Crosshead travel limits are set (refer to “[Set the crosshead limit stops](#)” on page [116](#)).
 - The value of load in the live display is near zero. If it is not, balance the load (refer to “[Balance a transducer configuration](#)” on page [118](#)).
 - The load limits are set in the software to a value that matches the maximum load capacity of the weakest component in the load string.
1. Install the strong specimen.
 2. Increase the load on the load string to the chosen preload value.

Caution

Do not attempt to increase the load by jogging the crosshead. The collision mitigation feature will stop the crosshead before the system reaches the desired load value.

- a Start Bluehill® and prepare to run a test using the specifically-designed test method, named **Preload Grips**. This method is located in the Templates directory within Bluehill®.
- b Enter values for Rate and Force and start the test.

The crosshead drives at the designated rate until it reaches the chosen preload value and the test stops.

3. Hand tighten all the locknuts on the grips and any intermediate couplings.
4. Reduce the load to zero.
5. Remove the specimen.

The load string is now preloaded and all the locknuts are tight and should not move during subsequent testing. The system is now ready to test.



When you next need to change grips or any other part of the load string, the locknuts will be too tight to loosen by hand. You will need to follow the procedure “[Unload the load string](#)” on page [101](#)

Unload the load string

If you have followed the procedure to preload the load string (“[Preload the load string](#)” on page 99) you will need to follow this procedure before you can change grips or any or any other part of the load string. The locknuts will be too tight to loosen by hand.

1. Install the strong specimen.
2. Increase the load on the load string to the chosen preload value.

Caution

Do not attempt to increase the load by jogging the crosshead. The collision mitigation feature will stop the crosshead before the system reaches the desired load value.

- a Start Bluehill[®] and prepare to run a test using the specifically-designed test method, named **Preload Grips**. This method is located in the Templates directory within Bluehill[®].
- b Enter values for Rate and Force and start the test.

The crosshead drives at the designated rate until it reaches the chosen preload value and the test stops.

3. Loosen all the locknuts on the grips and any intermediate couplings.
4. Reduce the load to zero.
5. Remove the specimen.

The loadstring is now unloaded and all the locknuts are loose so that you can change any component.

Chapter 6

Testing specimens

• Testing a sample	103
• Create a new sample.	110
• Calibrate a transducer.	111
• Set the zero displacement point.	115
• Crosshead limit stops	115
• Set the limits for a transducer	117
• Balance a transducer configuration.	118
• Stop a test	119
• Shut down the system.	121
• Troubleshooting	121

Materials testing systems are inherently hazardous. Read the chapter “[Risk reduction and safe use](#)” on page [25](#) before using the testing system.

Testing a sample

The following two procedures are guidelines for steps that you would typically go through when testing a group of specimens. Some steps include references to more detail in separate sections.

These scenarios assume that a test method has already been created that satisfies your testing requirements and provides required test parameters (e.g. specimen dimensions, testing notes) on the test workspace.

The two scenarios describe testing with and without an interlock.

An interlock is an optional accessory that changes the behavior of the system depending on whether the interlock circuit is open or closed. For example, the door on a protective shield may include an interlock. When the interlock circuit is open (e.g. the

shield door is open), the circuit is interrupted and the system is either disabled or restricted as defined by the Operator Protection settings.

Testing with no interlock

This test scenario assumes the system has no accessories with an interlock and that the start test method in Operator Protection settings is set to **Frame control** (the default).

Warnings



Set the load frame limit stops to limit crosshead travel, and set adequate transducer limits to ensure the safe operation of the testing system.

Set all available limits before using the system to avoid crosshead overtravel, contact between grips and fixtures, overloading any component of the load string, or overtravel of a contacting extensometer.



Hazard - do not allow more than one person to operate a testing machine.

Operator injury may result if more than one person operates the testing machine. For example, injury can occur if one person moves the crosshead or actuator while the other is working inside the hazard area between the grips or fixtures.



Crush hazard - take care when installing or removing a specimen, assembly, structure or load string component.

Installation or removal of a specimen, assembly, structure or load string component involves working inside the hazard area between the grips or fixtures. When working in this area, ensure that other personnel cannot operate any of the system controls. Keep clear of the jaws of a grip or fixture at all times. Keep clear of the hazard area between the grips or fixtures during actuator or crosshead movement. Ensure that all actuator or crosshead movements necessary for installation or removal are slow and, where possible, at a low force setting.



Flying Debris Hazard - Make sure that test specimens are installed correctly in grips or fixtures in order to eliminate stresses that can cause breakage of grip jaws or fixture components.

Incorrect installation of test specimens creates stresses in grip jaws or fixture components that can result in breakage of these components. The high energies involved can cause the broken parts to be projected forcefully some distance from the test area. Install specimens in the center of the grip jaws in line with the load path. Insert specimens into the jaws by at least the amount recommended in your grip documentation. This amount can vary between 66% to 100% insertion depth; refer to supplied instructions for your specific grips. Use any centering and alignment devices provided.



Flying Debris Hazard - Brittle specimens may shatter upon failure.

The high energies involved in testing can cause broken parts of a specimen to be projected forcefully some distance from the test area. Wear eye protection and use protective shields or screens whenever a risk of injury to operators and observers exists from the failure of a test specimen.



Select the correct test area for the test. An incorrectly set test area can cause unanticipated crosshead behavior. Press the Emergency Stop button if the frame moves in an unexpected direction.

An incorrectly set test area can cause unanticipated crosshead behavior and create a safety hazard that may damage the specimen or load cell. Verify the test area and test direction before starting a test.

1. Collect all specimens together that will make up the testing sample.
2. Identify each specimen, e.g. by marking. Identifying each specimen helps match it to the appropriate specimen number in the completed sample test report.
3. Start the frame and open the software.

The system is in **DISABLED** mode.
4. Ensure that the crosshead travel limits are set. Refer to [“Set the crosshead limit stops”](#) on page 116.
5. Ensure that limits are set for each transducer (displacement, force, strain, and user-defined). Refer to [“Set the limits for a transducer”](#) on page 117.
6. Press the **UNLOCK** button on the frame control panel to transition the system to **SET UP** mode.

The system is now restricted to the Operator Protection settings specified on the **Configuration > Frame** screen on the Admin tab.
7. In the software, create a new sample file. Refer to [“Create a new sample”](#) on page 110
8. Verify that the test area is correct in System Details. Select **Frame** under Method settings.
9. If necessary, calibrate the transducer configurations required by the test method. Refer to [“Calibrate a transducer”](#) on page 111.

If the frame was previously off, allow the load cell to warm up for at least 20 minutes to ensure stable readings.
10. Measure the required specimen dimensions for each specimen and enter the values into the appropriate fields in the operator inputs component of the test workspace.
11. Use the jog controls to move the crosshead to its starting position and set zero displacement. Refer to [“Set the zero displacement point”](#) on page 115.
12. Balance the Force transducer configuration. Refer to [“Balance a transducer configuration”](#) on page 118

13. Install the specimen into the grips. Refer to the documentation provided with the grips for details.

For example:

- pneumatic grips with the integrated air kit - refer to the manual addendum (M10-17666-EN) supplied with this manual for more details about the pneumatic grip air kit
- hydraulic grips - refer to the manual supplied with the grip pump for more details about hydraulic grips

14. Verify that the specimen is aligned properly in the grips.

15. Balance each of the remaining transducer configurations, e.g. strain. Refer to [“Balance a transducer configuration”](#) on page 118

16. Press the **UNLOCK** button to transition the system to **CAUTION** mode and then press the **START** button on the frame control panel to start the test.

CAUTION mode remains active for approximately two seconds after the unlock button is released. You must start the test before the system reverts back to **SET UP** mode.

The test will only start if the software displays the test workspace.

17. Upon starting the test, the various components on the test workspace update as the test proceeds. Some components will not update until the test is complete.

18. To stop the test before it completes, press the **STOP** button on the frame control panel.

Warning



In an emergency situation, press the large, round, red button on the frame to stop the test immediately and disable the frame.

Refer to [“Emergency Stop Button”](#) on page 119.

19. After the test is complete, the system transitions to **SET UP** mode.

20. Remove the specimen/specimen pieces from each grip.

If the specimen did not break, use the jog controls to relieve the applied force from the specimen before releasing the grips.

21. Complete any post-test inputs that the test method requires, e.g. final specimen dimensions, specimen notes.

22. If necessary, press the **UNLOCK** button to transition the system to **CAUTION** mode and then press the **RETURN** button on the frame control panel to return the crosshead to its starting position.

When the crosshead returns to its starting point, the system transitions to **SET UP** mode for the next specimen.

23. After all specimens are tested, select **Finish sample** on the Test tab.



Testing with an interlock

This test scenario assumes the system has an accessory with an interlock and that the start test method in Operator Protection settings is set to **Frame control** (the default).

Warnings



Set the load frame limit stops to limit crosshead travel, and set adequate transducer limits to ensure the safe operation of the testing system.

Set all available limits before using the system to avoid crosshead overtravel, contact between grips and fixtures, overloading any component of the load string, or overtravel of a contacting extensometer.



Hazard - do not allow more than one person to operate a testing machine.

Operator injury may result if more than one person operates the testing machine. For example, injury can occur if one person moves the crosshead or actuator while the other is working inside the hazard area between the grips or fixtures.



Crush hazard - take care when installing or removing a specimen, assembly, structure or load string component.

Installation or removal of a specimen, assembly, structure or load string component involves working inside the hazard area between the grips or fixtures. When working in this area, ensure that other personnel cannot operate any of the system controls. Keep clear of the jaws of a grip or fixture at all times. Keep clear of the hazard area between the grips or fixtures during actuator or crosshead movement. Ensure that all actuator or crosshead movements necessary for installation or removal are slow and, where possible, at a low force setting.



Flying Debris Hazard - Make sure that test specimens are installed correctly in grips or fixtures in order to eliminate stresses that can cause breakage of grip jaws or fixture components.

Incorrect installation of test specimens creates stresses in grip jaws or fixture components that can result in breakage of these components. The high energies involved can cause the broken parts to be projected forcefully some distance from the

test area. Install specimens in the center of the grip jaws in line with the load path. Insert specimens into the jaws by at least the amount recommended in your grip documentation. This amount can vary between 66% to 100% insertion depth; refer to supplied instructions for your specific grips. Use any centering and alignment devices provided.



Flying Debris Hazard - Brittle specimens may shatter upon failure.

The high energies involved in testing can cause broken parts of a specimen to be projected forcefully some distance from the test area. Wear eye protection and use protective shields or screens whenever a risk of injury to operators and observers exists from the failure of a test specimen.



Select the correct test area for the test. An incorrectly set test area can cause unanticipated crosshead behavior. Press the Emergency Stop button if the frame moves in an unexpected direction.

An incorrectly set test area can cause unanticipated crosshead behavior and create a safety hazard that may damage the specimen or load cell. Verify the test area and test direction before starting a test.

1. Collect all specimens together that will make up the testing sample.
2. Identify each specimen, e.g. by marking. Identifying each specimen helps match it to the appropriate specimen number in the completed sample test report.
3. Start the frame and open the software.
4. Ensure that the crosshead travel limits are set. Refer to [“Set the crosshead limit stops”](#) on page 116.
5. Ensure that limits are set for each transducer (displacement, force, strain, and user-defined). Refer to [“Set the limits for a transducer”](#) on page 117.
6. Press the **UNLOCK** button on the frame control panel to transition the system to one of the following:

The system is in **DISABLED** mode.

- **SET UP** mode. System transitions to this mode if the interlock is open and an operator has access to the test area. The system is now restricted to the Operator Protection settings specified on the **Configuration > Frame** screen on the Admin tab.



*If the interlock behavior is set to **Disable frame** then pressing the **UNLOCK** button with the interlock open has no effect. You must close the interlock to enable the frame.*

- **CAUTION** mode. System transitions to this mode if the interlock is closed and there is no access to the test area. The system can operate up to its full capacity.

7. In the software, create a new sample file. Refer to [“Create a new sample”](#) on page 110

8. Verify that the test area is correct in System Details. Select **Frame** under Method settings.
9. If necessary, calibrate the transducer configurations required by the test method. Refer to [“Calibrate a transducer”](#) on page 111.
If the frame was previously off, allow the load cell to warm up for at least 20 minutes to ensure stable readings.
10. Measure the required specimen dimensions for each specimen and enter the values into the appropriate fields in the operator inputs component of the test workspace.
11. Use the jog controls to move the crosshead to its starting position and set zero displacement. Refer to [“Set the zero displacement point”](#) on page 115.
12. Balance the Force transducer configuration. Refer to [“Balance a transducer configuration”](#) on page 118
13. Open the interlock. The system behavior depends upon how the interlock behavior is configured under Operator Protection:
 - **Disable frame** option: the system transitions to **DISABLED** mode when the interlock is open. You must close the interlock to enable the frame and move the crosshead, if necessary.
 - **Allow limited motion** option: the system transitions to **SET UP** mode when the interlock is open. You can use the jog keys to move the crosshead when the interlock is open. The crosshead is limited to the jog rate specified under Operator Protection.
14. Install the specimen into the grips. Refer to the documentation provided with the grips for details.
For example:
 - pneumatic grips with the integrated air kit - refer to the manual addendum (M10-17666-EN) supplied with this manual for more details about the pneumatic grip air kit
 - hydraulic grips - refer to the manual supplied with the grip pump for more details about hydraulic grips
15. Verify that the specimen is aligned properly in the grips.
16. Balance each of the remaining transducer configurations, e.g. strain. Refer to [“Balance a transducer configuration”](#) on page 118
17. Close the interlock.
The system transitions to **CAUTION** mode.
18. Press the **START** button on the frame control panel to start the test
The test will only start if the software displays the test workspace.
19. Upon starting the test, the various components on the test workspace update as the test proceeds. Some components will not update until the test is complete.
20. To stop the test before it completes, press the **STOP** button on the frame control panel.

Warning



In an emergency situation, press the large, round, red button on the frame to stop the test immediately and disable the frame.

Refer to “[Emergency Stop Button](#)” on page [119](#).

21. After the test is complete, the system transitions to **CAUTION** mode.

If the specimen did not break, use the jog controls to relieve the applied force from the specimen before opening the interlock to remove the specimen.

22. Open the interlock to remove the specimen pieces from each grip. The system behavior depends upon how the interlock behavior is configured under Operator Protection:

- **Disable frame** option: the system transitions to **DISABLED** mode when the interlock is open. You must close the interlock to enable the frame and move the crosshead, if necessary.
- **Allow limited motion** option: the system transitions to **SET UP** mode when the interlock is open. You can use the jog keys to move the crosshead when the interlock is open. The crosshead is limited to the jog rate specified under Operator Protection.

23. Close the interlock.

The system transitions to **CAUTION** mode.

24. Complete any post-test inputs that the test method requires, e.g. final specimen dimensions, specimen notes.

25. If necessary, press the **RETURN** button on the frame control panel to return the crosshead to its starting position.

26. After all specimens are tested, select **Finish sample** on the Test tab.



Create a new sample

To create a sample, you can either select an existing test method that contains the settings and parameters for the test (see below) or create a new method for the sample (refer to the Bluehill[®] online help and reference).

To select an existing method file:

1. Select **Test** on the **Home** screen.

2. Under **New Sample**, select a test method. You can either:
 - select a method shown under **Methods**. These are the most recently used method files.
 - select **Browse methods** to find a specific method file.

The system creates a sample based on the test parameters specified in the method file and advances to the Test tab.



*The sample is initiated when the system advances to the Test tab. It is not yet saved as a file. The sample will be saved as file upon finishing the sample or when you select the **Save** button on the Test tab.*

Calibrate a transducer

Automatic calibration of a force or strain transducer

Warning



Do not adjust the current calibration point value for an automatic calibration without first contacting Instron[®] Service. Adjusting the calibration point can negatively affect the validity of the data from the transducer.

A strain transducer can be an LVDT transducer. If the system identifies the strain transducer as an LVDT transducer, the Calibration point field becomes available for automatic calibration. The calibration point field is intended primarily for Instron[®] Service and should only be used by the service personnel. Contact Instron[®] Service for assistance.

1. Select  in the console area to open System Details.
2. In the System Settings area, select the icon for the transducer to open the Transducer Settings dialog.
3. Under Settings, select the transducer configuration in the **Transducer configuration** field.
4. Ensure that **Calibration type** is set to **Automatic**.

Automatic calibration uses the following basis for the calibration point value:

Force	50% of the full-scale load transducer
Strain	100% of the full-scale strain transducer

5. Set the transducer to its zero point.
For force, zero point means no load on the system.
For strain, zero point means the starting point of the strain transducer (e.g. extensometer)
6. Select **Calibrate**.
7. Follow the instructions provided in the Transducer Settings dialog and then select **OK** to proceed with the calibration.
Calibrating... displays in the transducer live display area during calibration.
8. The calibration was successful if a value displays in the transducer live display area and the transducer icon in System Details is no longer grayed.
9. Close the Transducer Settings dialog.
10. Close System Details.

The calibration is saved with the transducer configuration and is restored whenever the transducer configuration is selected.

The transducer is now calibrated and ready for testing. The transducer must be associated with a measurement in a method. Verify that the method used for testing includes a measurement that is linked to the transducer configuration for this transducer.

Manual calibration

During a manual calibration, you apply a measured physical force to the transducer and the system calibrates on the signal that is output as a result of that force. For force calibration, you can hang a measured weight from the load cell. For strain calibration, you can install the extensometer on a specially designed calibration jig to apply a precise deflection to the extensometer.

The system only saves the values entered for a manual calibration after there is a successful calibration. If you select a different transducer configuration or close the dialog before calibrating a transducer configuration, the calibration fields revert to the default values for that configuration.

Manual calibration of a rationalized force or strain transducer

1. Select  in the console area to open System Details.
2. In the System Settings area, select the icon for the transducer to open the Transducer Settings dialog.
3. Under Settings, select the transducer configuration in the **Transducer configuration** field.

4. Set **Calibration type** to **Manual**.
5. Enter a value for the calibration point. This value is the force (for a load cell) or deflection (for an extensometer) that you apply to the transducer during calibration.
For example, to calibrate a 100 kN load cell using a 50 kN weight, the full scale value is 100 kN and the calibration point is 50 kN.

The range for a valid calibration point value is between:

	Force (% full scale)	Strain (% full scale)
Minimum	2	2
Maximum	105	110
If you change the units for a field, the software converts the corresponding value to its equivalent value in the new units. Verify that the value is correct for the specified units.		

6. Select **Calibrate**.
7. Follow the instructions provided in the Transducer Settings dialog and select **OK** to proceed with the calibration:
 - a Set the transducer to its zero point or gauge length point.
 - b Deflect the transducer to its calibration point using a weight (load cell) or a calibration jig (extensometer).
For force, if you have a load cell with an associated electrical calibration circuit, you can use this to apply an electrical signal instead of applying a physical force to the load cell.
 - c Return the transducer to its zero point or gauge length point.

Calibrating... displays in the transducer live display area during calibration.
8. The calibration was successful if a value displays in the transducer live display area and the transducer icon in System Details is no longer grayed.
9. Close the Transducer Settings dialog.
10. Close System Details.

The calibration is saved with the transducer configuration and is restored whenever the transducer configuration is selected.

The transducer is now calibrated and ready for testing. The transducer must be associated with a measurement in a method. Verify that the method used for testing includes a measurement that is linked to the transducer configuration for this transducer.

Manual calibration of a non-rationalized force or strain transducer

1. Select  in the console area to open System Details.

2. In the System Settings area, select the icon for the transducer to open the Transducer Settings dialog.
3. Under Settings, select the transducer configuration in the **Transducer configuration** field.
4. Set **Calibration type** to **Manual**.
5. Enter the full scale value of the transducer.
6. For strain transducers, enter the gauge length of the extensometer.
The system must know the gauge length of the installed extensometer in order to calculate strain values for display and for further calculations.
7. Enter a value for the calibration point. This value is the force (for a load cell) or deflection (for an extensometer) that you apply to the transducer during calibration.
For example, to calibrate a 100 kN load cell using a 50 kN weight, enter 100 kN as the full scale value and 50 kN as the calibration point.
The range for a valid calibration point value is between:

	Force (% full scale)	Strain (% full scale)
Minimum	2	2
Maximum	105	110
If you change the units for a field, the software converts the corresponding value to its equivalent value in the new units. Verify that the value is correct for the specified units.		

8. Select **Calibrate**.
9. Follow the instructions provided in the Transducer Settings dialog and select **OK** to proceed with the calibration:
 - a Set the transducer to its zero point or gauge length point.
 - b Deflect the transducer to its calibration point using a weight (load cell) or a calibration jig (extensometer).
For force, if you have a load cell with an associated electrical calibration circuit, you can use this to apply an electrical signal instead of applying a physical force to the load cell.
 - c Return the transducer to its zero point or gauge length point.

Calibrating... displays in the transducer live display area during calibration.
10. The calibration was successful if a value displays in the transducer live display area and the transducer icon in System Details is no longer grayed.
11. Close the Transducer Settings dialog.
12. Close System Details.

The calibration is saved with the transducer configuration and is restored whenever the transducer configuration is selected.

The transducer is now calibrated and ready for testing. The transducer must be associated with a measurement in a method. Verify that the method used for testing includes a measurement that is linked to the transducer configuration for this transducer.

Set the zero displacement point

Setting the zero displacement point sets the transducer value to zero. This identifies the current position as the starting point from which total crosshead displacement is measured during a test. This effectively balances the displacement transducer.



“Zero displacement” is also known as “Reset the gauge length” or “Balance displacement”.

1. Use the jog controls to move the crosshead to its starting position for the test.
2. Select  in the console area to open System Details.
3. In the System Settings area, select the Displacement settings icon to open the Transducer Settings dialog.
4. Under **Displacement**, select the **Zero** button.
5. Close the Transducer Settings dialog.
6. Close System Details.



*Shortcut: If you have Displacement set up in your live displays, select it and select the **Zero** button in the dialog that appears.*

Crosshead limit stops

Warning



Crush hazard - you must set the crosshead travel limits as protection against unexpected crosshead movement.

Although Bluehill lets you set limits of travel in the software, you must set the crosshead travel limits as well. These hardware limits provide an absolute limit of travel that operates independently of the software.

Set the crosshead limits stops after you have established the crosshead starting position, but before you start a test.

The crosshead limit stops are two adjustable blocks mounted on the limit switch rod, which is located inside the column of the machine, as shown in [Figure 29](#) on page [117](#). Limit stops (1 and 2) have thumbscrews that you tighten and release by hand, and you can move them to any position on the limit rod. Position these stops just beyond the test parameters to prevent crosshead over-travel. When the crosshead reaches the maximum pre-set travel, the limit switch actuator (3) contacts one of these stops. Contact between the limit actuator and the limit stop moves the limit switch rod (4) and activates the limit switches. This stops crosshead motion.

There is an additional, second level of crosshead limit stop that is activated if the first level switch malfunctions. Activating a second-level limit switch disables the drive system so you cannot move the crosshead. The second level limits are internal to the machine. They are calculated relative to the first level limits and cannot be independently set.

Set the crosshead limit stops

1. Ensure that the crosshead is stationary and that the test parameters are set.



When setting limit stops, allow for an additional 3 mm of crosshead travel after the actuator activates a limit stop. There is a small delay time from the point when the actuator hits the limit stop and when the message relays to the limit switches located in the frame base.

2. Set the upper limit stop at a position just above the expected maximum crosshead travel in the upward direction when tension testing, or just above the test starting point when compression testing. Tighten the stop securely on the limit rod.
3. Set the lower limit stop at a position just below the starting position when tension testing or just below the expected maximum crosshead travel in the down direction when compression testing. Tighten the stop securely on the limit rod.

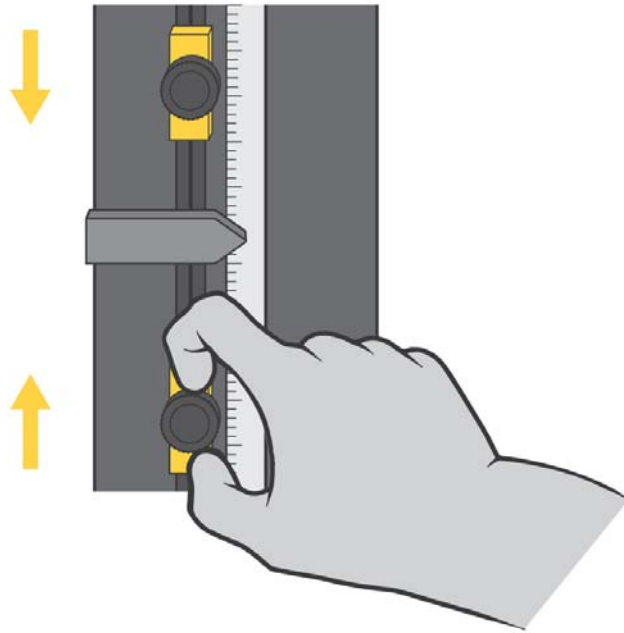

Figure 29. Setting Limit Stops

Caution

Do not use limit stops to end a test.

The limit stops are not intended to be an end of test condition to end every test. Repeated use of the limit stops in this way may cause excessive wear, which can result in the limit stop failing to stop the crosshead. Proper end of test conditions can be set from the software. Refer to the online help system for further assistance.

Move Off a Crosshead Limit Stop

The test stops if the crosshead contacts the upper or lower limit stops. If this happens, use the jog controls to move the crosshead away from the limit.

Set the limits for a transducer

1. Select  in the console area to open System Details.

2. In the System Settings area, select the icon for the transducer to open the Transducer Settings dialog.
3. Select **Limits**.
4. Select **Enabled** to activate the Maximum and Minimum limits.
The system activates the related fields. If **Enabled** is not selected, the system does not monitor the transducer for that limit value.
5. Enter a value for the Maximum limit.
If you change the units for a field, the software converts the corresponding value to its equivalent value in the new units.
6. Enter a value for the Minimum limit.
7. Close the Transducer Settings dialog.
8. Close System Details.

These settings are saved with the transducer configuration and are restored whenever the transducer configuration is selected.

Balance a transducer configuration

Calibrate the transducer before you balance it.

1. Make sure that no specimen is installed.
2. Select  in the console area to open System Details.
3. In the System Settings area, select the icon for the transducer to open the Transducer Settings dialog.
4. Under Settings, select the transducer configuration in the **Transducer configuration** field.
5. Select **Balance**.
The system removes any offsets caused by minor electrical or mechanical changes and resets the current transducer value to zero.
6. Close the Transducer Settings dialog.
7. Close System Details.

You can also:

- Select the live display that represents the transducer in the console area of the main screen and use the **Balance** button in the dialog.
- set a soft key to **Balance** a specific source transducer.

- set a soft key to **Balance all**.

Stop a test

You can stop a test by using hardware controls on the machine or settings in the software.

Emergency Stop Button



Figure 30. Emergency Stop Button

The Emergency Stop button on the testing system is a large, round, red button with a yellow background. Press this button to stop the test as soon as possible when a condition develops that:

- Could affect the safety of persons operating the system.
- Could damage the specimen, load frame, or test fixtures.

Investigate and resolve the situation that caused the use of the Emergency Stop button before you reset the system.

When operated, the Emergency Stop button locks into the closed position and the system is disabled until you reset the button and re-enable the load frame.

Warning



If you are using an integrated air kit with a foot switch to control a set of pneumatic grips, be aware that pressing the Emergency Stop button to disable the frame will also deactivate the grips, causing them to open.

With an integrated air kit, any action that disables the frame will also open the grips.

Warning



If you are using hydraulic grips, be aware that pressing the Emergency Stop button to disable the frame will lock the grips in their current position, prohibiting any further motion.

Re-enable the load frame

To reset the Emergency Stop button, rotate the button a quarter-turn clockwise until it resets.

The steps to re-enable the frame are different between a system with and without an interlock.

- In a system without interlocks:
 - a. Press the **UNLOCK** button on the frame control panel.

The frame proceeds to **SET UP** mode.
- In a system with interlocks:
 - a. Open the interlock.
 - b. Close the interlock.
- In addition, in a system with interlocks where the interlock behavior is configured under Operator Protection to **Allow limited motion**:
 - a. Press the **UNLOCK** button on the frame control panel.

Crosshead Limit Switches

The test stops if the crosshead contacts the upper or lower limit stops. If this happens, use the jog controls to move the crosshead away from the limit.

Software Event

When the system encounters a pre-set limit or event set from the software, the test stops. The crosshead stops moving.

Shut down the system

Wait until the system completes all active tasks before shutting it off or disconnecting the electrical power.

Shut off the power to the system before you:

- Perform any maintenance procedure on the load frame.
- Disconnect the main power cable.
- Move the load frame.
- Connect or install optional components or accessories.

Turn the system off

1. Complete the test.
2. Remove the specimen.
3. Save any samples and test methods that may be open.
4. Exit the software and turn off the computer.
The **DISABLED** indicator flashes.
5. Shut off all any other components or accessories to the test system.
6. Switch the power for the load frame to the Off (O) position. The **DISABLED** indicator light no longer illuminates.

Troubleshooting

A Software Transducer Limit Trips

If the system trips a transducer limit, you must remove the condition that caused it to trip and the limit resets.

For example, if you set a load of 10 kN and the crosshead moves to or beyond a point that imposes a load of 10 kN on the specimen, you cannot proceed until you remove the limit condition.

Use the jog buttons to drive the crosshead in the direction necessary to remove the limit condition.

A Crosshead Travel Limit Trips

The test stops if the crosshead contacts the upper or lower limit stops. If this happens, use the jog controls to move the crosshead away from the limit.

Second Level Limit Stops

The second level limit switch acts as a backup if the first level switch (the limit stops) malfunctions. Activating a second-level limit switch disables the drive system so you cannot move the crosshead. The second level limits are internal to the machine. They are calculated relative to the first level limits and cannot be independently set.

Warning



Hazard - Identify and resolve the condition that caused the operation of the secondary overtravel limit before you use the testing system.

Operation of a secondary overtravel limit indicates a serious problem with your testing system, not least that the primary overtravel limit may have failed. Identify and resolve the condition that caused the secondary overtravel limit to trip before you use the testing system again. Contact Instron[®] Service for assistance.

You press the Emergency Stop button

Refer to “[Emergency Stop Button](#)” on page [119](#).

Chapter 7

Maintenance

• Preventive Maintenance	123
• General Maintenance Procedures	128
• Troubleshooting for Load Cells	130
• Ancillary parts	130

Warnings



Hazard - Only qualified personnel, trained to service Instron[®] machines, should perform all internal maintenance procedures.

Instron[®] machines must operate within stringent specifications. In order to keep the system working within the stated safety specifications, a professionally trained and qualified technician must perform most maintenance procedures. If unqualified personnel perform any maintenance procedures not described in this manual, the machine may not perform to its stated specifications.



Hazard - Do not remove covers to any component of your system, unless it is specified in a procedure.

There are dangerous voltages and rotating machinery inside the machine that may cause bodily injury or damage to equipment.

Preventive Maintenance

Preventive maintenance is the periodic inspection, cleaning, and lubrication of the test system. The following sections provide guidelines for preventive maintenance.

To ensure that the frame continues working at its optimal performance, it is recommended that the machine receive an annual service check. Instron[®] Service can perform this annual service, and replace any damaged or worn parts to ensure that your machine operates to its stated specifications.

Instron[®] offers many service agreements that provide a variety of services, including annual service visits. Contact Instron[®] Service for details on a service agreement or contract that best matches your needs.

If your testing application generates debris, particularly conductive or abrasive dust, refer to “[Ingress Protection](#)” on page 29 for additional maintenance advice.

Daily Maintenance Checks

Before operating the system each day, ensure:

- All cable connections are tight and secure.
- All grips, fixtures and accessories are free of dirt, damage and deformation.
- The load frame is level. If an adjustment is necessary, refer to “[Level the load frame](#)” on page 33.
- Signal and power cables have adequate slack to prevent excessive strain on connectors.
- All cables and pneumatic hoses are free of wear and chafing. Re-route them if necessary, and replace any that are damaged.
- After turning on the system, make sure that power is adequately supplied to the electronics.

Correct any problems before you operate the testing system. If you require assistance, contact Instron[®] Service.

Periodic Inspections

Every six to twelve months, perform the following inspections:

- Visually inspect the machine for any loose fittings. Check the limit stops, cable connections, and connections for any accessories that are attached to the machine. Tighten any loose connections that you may find.
- Operate the crosshead through the full range of motion. It should move smoothly with no unusual noise, or erratic motion. If it does not, refer to [Table 8](#) on page 126 for lubrication recommendations.
- Test the limit stops to ensure they are in working order. Refer to “[Test Limit Stops](#)” on page 128.
- If you have any additional safety equipment added to the machine, test the equipment to ensure it is in working order.

If you notice any problems resulting from these inspections, contact Instron[®] Service for immediate assistance.

Cleaning

Caution

Do not clean with solvents or abrasive cleaners. Some household or commercial cleaners can react with painted surfaces or panel markings.

Do not apply excessive amounts of detergent cleaner. It may seep into electrical circuits within the base and cause equipment failure.

Do not use too much oil. It attracts abrasive particles that may accelerate wear.

Use low pressure air to blow dust. Do not direct the air stream directly at sensitive components.

It is recommended that the machine be cleaned weekly, or more often if it is operating in a dusty or dirty environment.

To clean the load frame, wipe exterior surfaces of the load frame with a moist cloth.

If your machine has a maximum capacity of 50 kN or greater (all floor models and some table models) and if the central mounting area on the base beam is exposed (no base adapter is in place) then you must regularly lubricate the mounting area with oil to prevent corrosion. If you regularly use a base adapter, then you do not need to lubricate this area (refer to “[Lubrication](#)” on page [125](#)).

Lubrication

The following areas of the machine will require periodic lubrication:

- **Ballscrews** - The ballscrews are lubricated via a ballnut that is located on the crosshead where the ballscrew intersects the crosshead. As the crosshead moves up and down, the ballnut disperses a thin layer of lubricant over each ballscrew as the ballscrew passes through the ballnut. Periodically, the ballnut must be filled with lubricant to ensure that the ballscrews remain well lubricated. The ballnut must be maintained and filled in accordance with [Table 8](#) on page [126](#).

Inspect the ballscrew and lubricate more frequently if any of the following conditions exist:

- There is high-load or high-speed testing.
- There is long-term, continuous movement of the crosshead.
- The system operates in a dirty environment.
- There are high-load cycling tests.

- **Guide columns** - The guide columns require only a thin film of lubrication. It is recommended that the machine be re-lubricated every two years.

The guide column is located behind the ballscrew. If you suspect that the guide column needs lubrication, contact Instron[®] Service for assistance.

Table 8. Lubrication Requirements for Ballnuts

Recommended Lubricant	Interval	Instron [®] Part Number
Lithium based water resisting grease - NLGI Class 2 (DIN51825 class K2k LS2) Equivalents: Lubriplate: Lubriplate 1200-2 Mobil: Mobilux [®] 2 BP: Energrease [®] LS2 Shell: Alvania [®] R2	1000 ¹ hours or 36 months of operating time ²	105-1-1057 (small can of lubricant)

1. If the system is used more than 100 hours per month, inspect the lubricated area periodically and increase lubrication frequency as required.
2. Operating time is defined as time of crosshead movement, not the length of time the system has been powered on.

Lubricate ballnuts

Refer to [Figure 31](#) on page [127](#).

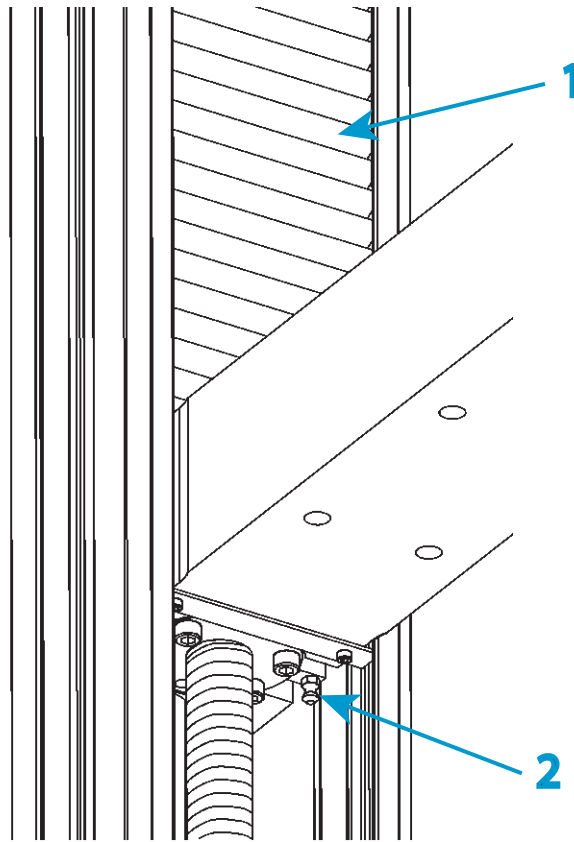

Figure 31. Ballnut lubrication

Legend for [Figure 31](#)

Label	Description
1	Ballscrew cover
2	Ballnut nipple

1. Ensure that the power switch is in the Off (0) position and disconnect the power cable from the power source. Verify that no LEDs are illuminated on the frame control panel.
2. Detach the bottom ballscrew cover from the crosshead and slide it to the frame base.
3. Use a grease gun to apply the grease through the ballnut nipples on both columns. It is not necessary to remove the guide column covers.
4. Fill the ballnuts until grease begins to ooze from the top of the nut. Wipe away the excess grease.
5. Re-attach the bottom ballscrew cover to the crosshead.

6. Reconnect the power cable to mains power and turn on the system. Verify that the white **DISABLED** indicator on the frame control panel illuminates.
7. Use the jog controls to move the crosshead over the full stroke of the frame to distribute the grease in the ballnut and coat the ballscrew shaft.
8. Before you carry out any testing, perform the procedure described in “[First time startup](#)” on page 50.

General Maintenance Procedures

General maintenance procedures are the procedures that you can perform should it become necessary. These procedures do not require an Instron[®] service technician, although assistance is available. Contact Instron[®] Service for assistance.

Test Limit Stops

It is recommended that you periodically test both the first and second level limit stops on the load frame.

1. Ensure that the system is on and the crosshead is stationary.
2. Secure one of the limit stops (either the upper or lower limit stop) to the limit switch rod.
3. Firmly hold the yellow part of the limit stop to gently move the stop either downward (in compression) or upward (in tension) about 3 mm (1/8 in).
A first level limit warning displays on the computer.
4. Repeat [Step 3](#) moving the limit stop another 3 mm (1/8 in) in the same direction.
A second level limit warning and frame disabled warning displays on the computer.
The white LED above the **DISABLED** indicator on the frame control panel illuminates.
The frame disabled warning indicates that the limit stops are working correctly. If the frame disabled warning does not display, contact your local Instron[®] Service office for assistance.
5. Re-enable the frame (refer to “[Re-enable the load frame](#)” on page 120).

The frame is now ready to resume testing.

Replace a Fuse

Warnings



Electrical Hazard - Shut down the system and disconnect the power cable from the main power source before replacing a fuse. Dangerous voltages can cause personal injury.



Hazard - Do not remove covers to any component of your system, unless it is specified in a procedure.

There are dangerous voltages and rotating machinery inside the machine that may cause bodily injury or damage to equipment.

Caution

Replace a fuse with the same type and size as the original. Installing the wrong fuse could damage the electrical circuits inside the machine.

1. Ensure that the power switch is in the Off (0) position and disconnect the power cable from the power source. Verify that no LEDs are illuminated on the frame control panel.
2. Insert a small flat-head screwdriver into the middle of the connector and pry out the fuse holder, as shown below.

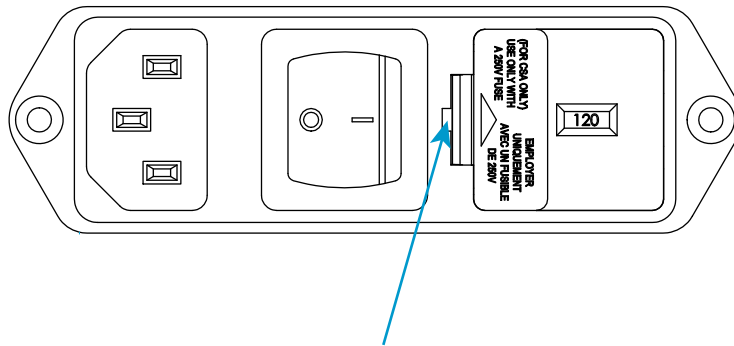

3. Remove the fuse holder from the power input connector and remove the fuses.
4. Install new fuses in the holder. Spare fuses are supplied with the system (refer to [“Ancillary parts”](#) on page 130).
5. Re-install the fuse holder into the connector.
6. Reconnect the power cable to mains power and turn on the system. Verify that the white LED above the **DISABLED** indicator on the frame control panel illuminates.

Troubleshooting for Load Cells

Instron[®] load cells, in general, are electrically calibrated, self-identifying and rationalized. Approximate resistances are given that can verify a possible broken gauge, or a faulty connector or cable.

If a strain gauge in a cell has been badly overstressed, but still maintains its electrical continuity, the cell may show a higher than normal amount of creep. If a gauge has become improperly bonded due to degradation in use, the cell may exhibit a combination of general instability in its balance point, together with a large amount of creep. Difficulties of this sort rarely appear as an instability in the calibration of the cell.

If a load cell has been overloaded, the load-sensitive member may be permanently deformed to the extent that the proper dimensional alignments inside the cell are no longer maintained. For example, if the position of the central spindle is changed, this can result in the balance point shifting abruptly as the cell is loaded or unloaded.

To check the load cell, substitute another cell to re-check the test results carefully. If your results differ significantly from the original test results, then the original load cell may be damaged. However, many of the symptoms described above can also arise from a faulty load sensor conditioner, or possibly a mechanical adjustment.

If you suspect that a cell may be damaged, contact Instron[®] Service to arrange return of the load cell for analysis and possible repair.

Ancillary parts

This section lists the ancillary parts that are included with the system upon delivery. These components are either required to complete the installation, or facilitate setting up load cells and accessories on the load frame. Keep these components in a safe place.

Parts list

Table 9. Ancillary parts

Description	Part Number	Quantity	Purpose
Cable tie hook and loop	11-10-1027	5	Cable management
Cable clip, 6-12 mm	11-6-60	3	Secures cables to the frame

Table 9. Ancillary parts (Continued)

Description	Part Number	Quantity	Purpose
Mechanical tensioner kit	A636-167	1	Installation kit for 30 kN and 50 kN load cells. Only included with 30kN, 50kN and 100kN capacity load frames.
M16 x 100 screw	201V85	1	Load cell installation screw and washer combinations. Refer to “Install the load cell” on page 1
M16 x 80 screw	201V83	1	
M10 x 140 screw	71-63-1169	1	
M10 x 120 screw	201V632	1	
M10 x 130 screw	201V633	1	
M10 x 90 screw	201V62	1	
M10 x 70 screw	201V60	1	
M10 x 40 screw	201V57	3	
M10 washer	610J9	3	
M16 oversized washer	610K12	1	
M16 washer	610J12	3	
Pin 3mm diameter, 10mm long	705K84	3	
Pin 3mm diameter, 12mm long	705K85	3	Load cell anti-rotation pin
Locating ring	T1335-1048	1	Locating ring for base - 40mm diameter for M30 thread
M10 spacer	T604-90	1	Use with M10 screws for load cell attachment
Fuse, 10A Time lag, 5 x 20mm glass high surge	27-2-233	2	Protection from electrical surges
Compression spring	66-4-23	1	Compression springs for different base adapters.
Compression spring	66-4-5	1	
Compression spring	66-5-6	1	
Hex wrench key set, 1.5 to 10 mm	80-1-1011	1	Tools for maintaining the frame and installation of accessories
Thin open-ended wrench, 16mm/17mm	P632-482	1	Tool for adjustment of feet on load frame

Table 9. Ancillary parts (Continued)

Description	Part Number	Quantity	Purpose
Wrench, open end, thin, 18 x 19mm	P636-681	1	Used to adjust the feet to level the load frame
Tool socket driver 14 mm key	80-3-50	1	Used for installation of 10kN load cell
8 mm bit - 1/2 in drive	80-3-13	1	Tool for tightening M10 screws
Torque wrench	80-9-9	1	Provides correct installation torque for load cell and base adapter attachment screws
Retainer clip for 0.5 in diameter pin	T1223-1053	2	Prevents the grip coupling pin from sliding out during testing
Accessories slot T-nut	T1697-1307	3	Installing accessories onto the column cover
Retaining pin, grip coupling	T29-515	1	Secures the grip coupling
3 MTS Ground cable	A712-213	1	Used to connect the frame to a suitable ground where the mains power supply is not grounded
Converter Type D to Type O	2501-346	1	Allows use of accessories with Type O interface.
CAT5E patch cable, 3m black	P636-647	1	For communication between the load frame and the Bluehill [®] Operator Dashboard.

Table 10. Ancillary parts - 34TM-100 only

Description	Part number	Quantity	Purpose
Bushing, crosshead center bore	T636-1221	1	Required for installation of load cells up to 50 kN
Locating ring, 60 mm outer diameter, 40 mm inner diameter	T636-1212	1	Required for installation of load cells up to 50 kN
M10 x 130 screw	201V633	6	Used for installation of 2530-100 kN load cell

create	
with existing method	110
sample file	
create	
with existing method	110
start	
new sample	
with existing method	110
support	23

T

technical support	23
test	
create new sample	
with existing method	110
Testing	104
testing safety limits	128
Testing with an interlock accessory	107
transducer	
balance	118
calibrate	111
limits	
set	117
travel limits	
second level limits	122
testing	128
troubleshooting load cells	130



www.instron.com