

3400 Series

Universal Testing Systems





INSTRON

5kN



Powered by Bluehill® Univer

0 Zero Displacement

Cracking Security off Live Inactive No test type Sample Closed Method Closed

CRACKING
Always wear safety glasses when using this machine. Do not touch the specimen or the grips during the test. Do not touch the grips when the machine is powered on.

Control panel with a red emergency stop button, a yellow button, and a keypad with various function keys.

3478F-5



For over **80 YEARS**, the Instron® brand has been widely recognized for producing some of the most advanced mechanical testing systems in the world. Our systems are designed by industry experts, vetted by active members of major standards organizations, and supported by a global network of skilled and experienced service technicians. This comprehensive approach allows us to back each Instron system with an unmatched level of industry and application expertise designed to support it throughout its lifetime.



1,500+ employees
A highly-educated, experienced, and diverse workforce



Representing **160 countries**, speaking **40+ languages**

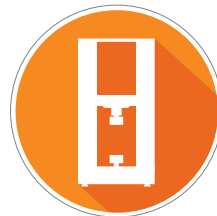

50,000+ systems installed worldwide



80 years of engineering and manufacturing testing systems

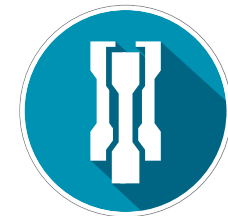

Diverse product range for nearly all global markets and industries

SOLUTIONS FOR ALL OF YOUR TESTING NEEDS

Application-Based Testing Solutions

The 3400 Series universal testing machines range in capacity from 500 N to 300 kN and are designed to meet all of your force testing needs. Instron's patented Operator Protect system architecture makes the 3400 Series simpler, smarter, and safer than ever before.



Single Column Testing Systems

For low force applications, the 3400 Series single columns provide up to 5 kN capacity available in standard and extra height options.

Table Model Testing Systems

For higher force applications, the 3400 Series dual column table models provide up to 100 kN capacity available in standard and extra height options.

SCAN THE QR CODE to learn more
and see the 3400 Series in action.



Floor Model Testing Systems

For the highest force applications, the 3400 Series floor models provide up to 300 kN capacity available in short base and tall base options.

HOW WILL THE 3400 SERIES MEET MY NEEDS?

Application-Based Testing Solutions

Instron® systems are routinely found in industries that require the testing of plastics, metals, elastomers, and packaging. Some of our key applications can be found in the biomedical, automotive, electronics, and raw materials industries.

The 3400 Series universal testing machines are designed to perform tensile, compression, flex, peel, puncture, friction, shear tests, and more. The systems are compatible with hundreds of grips and fixtures found in Instron's expansive accessory catalog.

SCAN THE QR CODE
to see Instron's full
Accessories Catalog.



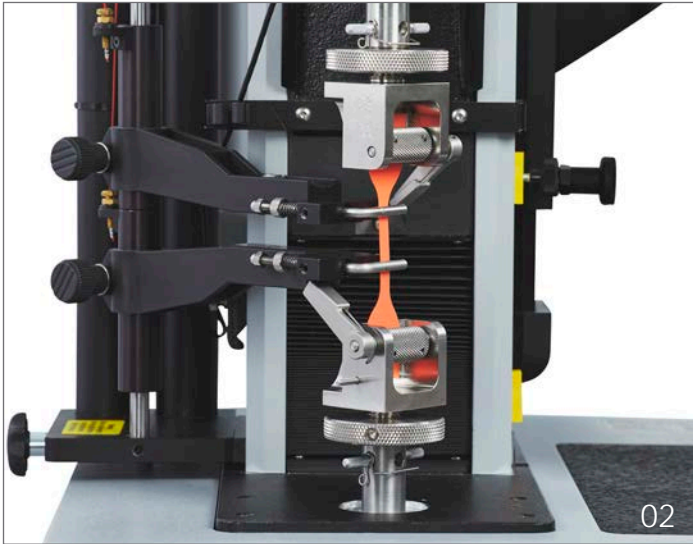

Tensile Testing

- 01 Pneumatic Side Action Grips
- 02 Eccentric Roller Grips
- 03 Wedge Action Grips
- 04 Webbing Capstan Grips
- 05 Pneumatic Cord and Yarn Grips
- 06 Screw Side Action Grips
- 07 Self-Tightening Roller Grips

HOW WILL THE 3400 SERIES MEET MY NEEDS?

Application-Based Testing Solutions

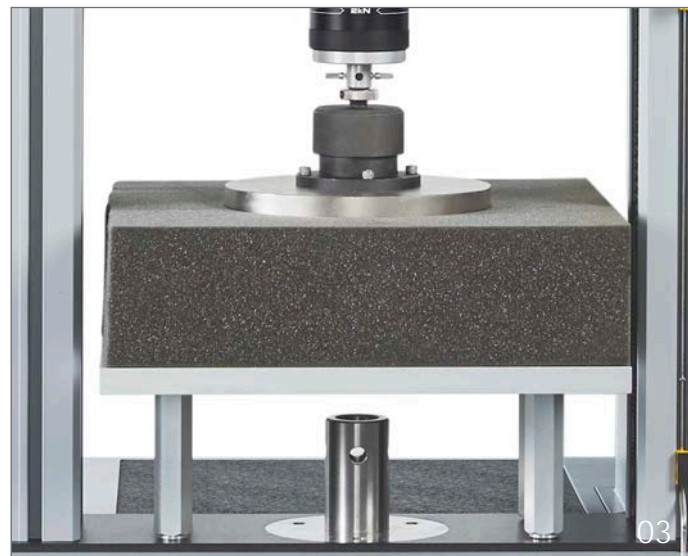

Compression and Flexure Testing

- 01 Syringe Compression Fixture
- 02 Component Test Plate and 3-Jaw Chuck
- 03 Perforated Compression Fixture with Swivel Platen
- 04 Compression Platens
- 05 Three-Point Bend Fixture



06

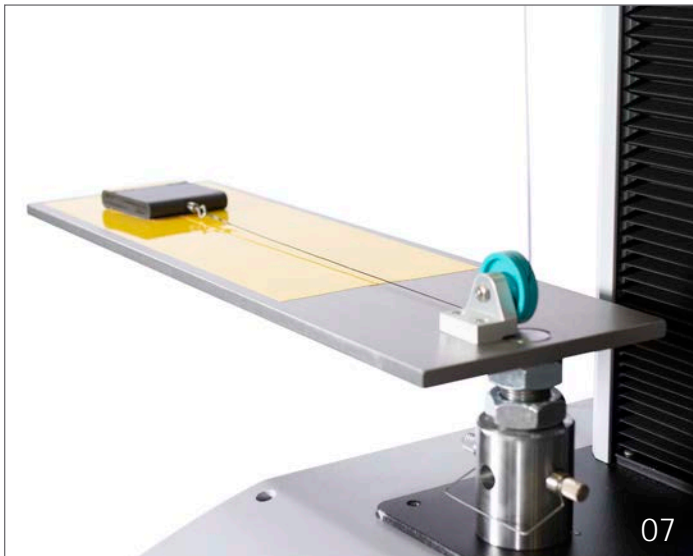

07

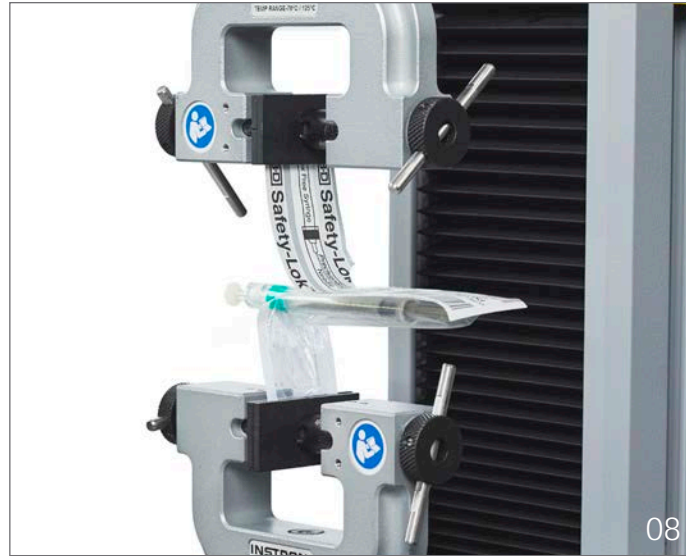

08



09



10

Peel, Tear, Puncture, and Friction Testing Solutions

- 06 50 N Pneumatic Side Action Grips
- 07 Coefficient of Friction Fixture
- 08 T-Peel Test with Screw Side Action Grips
- 09 Variable Angle Peel Fixture
- 10 Ball Burst Puncture Fixture



Simpler

Powered by Bluehill® Universal

The 3400 Series universal testing systems are powered by Instron's Bluehill Universal software. Equipped with easy-to-understand icons and workflows, Bluehill Universal makes it simple to train users and set up tests, helping you maximize lab efficiency while minimizing costly errors.



QuickTest

For when you need results fast, QuickTest allows you to enter a few simple parameters and run your test within seconds.



Pre-Loaded Templates

Bluehill Universal includes an extensive library of pre-configured methods for some of the most commonly used ASTM, ISO, and EN standards. The methods are packaged in modules that are specific to your testing application.



Prompted Tests

Workflows guide you through the entire testing process with step-by-step instructions, ensuring that your tests remain repeatable, simple, and error-free. The prompts are customizable with your own text and images.



TestProfiler

Build simple cyclic tests that include ramps, holds, and triangle waves. Conditional logic allows you to create looping patterns that help re-create real-life scenarios within tests.



TestCam

Connect a USB webcam to experience point-by-point video playback, allowing you to view the test even after it has finished.

SAFER

Safety Without Sacrificing Throughput



Operator Protect

The 3400 Series is built on Instron's patented Operator Protect architecture. An intelligent workflow keeps equipment and operators safer by controlling system status from setup to test completion.



Built-In Safety Coaching

The 3400 Series provides clear visual feedback regarding the system status at all times, making it easy to understand when the system is in a safe setup mode. It also provides a clear reminder to exit the test space once these safety limits are removed.



Smart-Close Air Kit

Finger pinch hazards from low-force pneumatic grips are reduced through lower grip-closing pressure and restricted speed during the setup phase of your test.

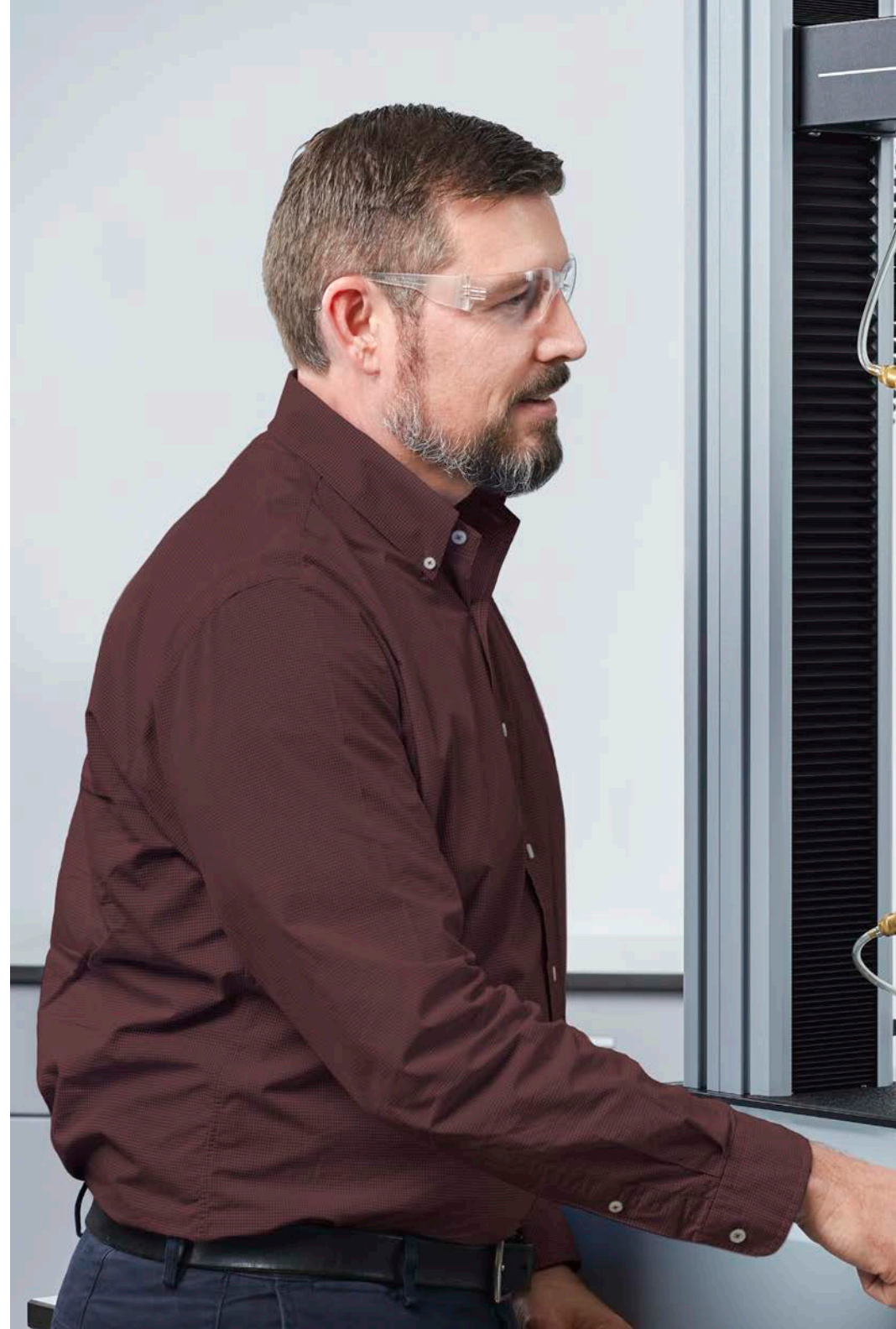



Operator Panel

The 3400 Series brings system controls closer than ever before with the all-new operator panel. Improve ergonomics and throughput by starting and stopping tests, jogging the crosshead, and returning to the starting position directly from the instrument.

Status at a Glance

Monitor the system status with indicator lights and corresponding Safety Coaching messages in Bluehill® Universal.

Variable Speed Jog

During Set Up mode, your system will default to a safe speed appropriate for an operator to work in the test space.

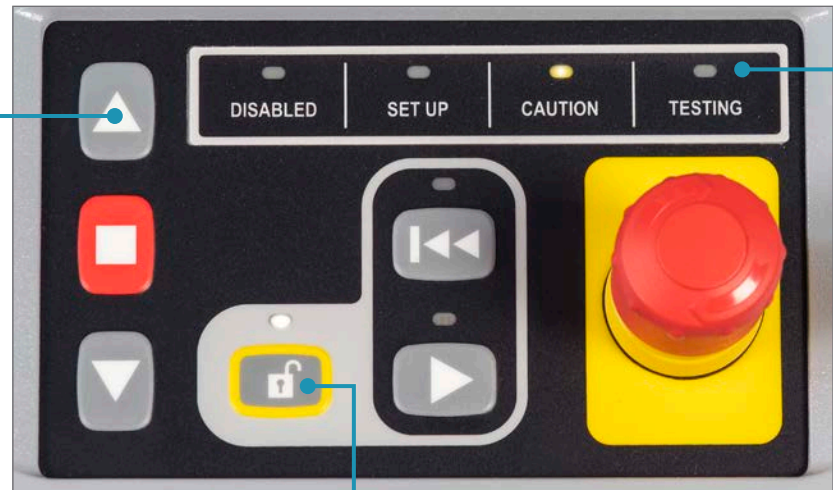

Virtual Interlock

With Instron's patent-pending system architecture, the machine's movement is restricted to prevent unintended motion of the crosshead.

SMARTER

Protecting Your Investment

Collision Mitigation

Reduce damage to equipment and delicate specimens by stopping the crosshead if force is detected upon return or during a jog.

Load Cell Overload Protection

The 3400 Series systems automatically stop when the load cell reaches maximum capacity to prevent damage to the load cell, system, and accessories.

Built to Last

Powered by maintenance-free brushless AC servomotors, the 3400 Series is designed for longevity. All Instron® electromechanical systems are equipped with guidance columns in addition to preloaded ball screws for increased robustness.



SUPPORT FOR THE LIFE OF YOUR EQUIPMENT

Protecting Your Investment

Instron® is one of the largest suppliers of materials testing systems in the world. Our reliable systems are engineered to perform critical tests around the clock. And when questions arise or support is needed, we offer a wide range of resources to ensure you get the help you need, quickly and efficiently.



Instron Connect



Instron Connect allows you to securely share your screen with Instron service professionals and submit service requests directly through your test system. You can also use this portal to easily send test methods and sample data files for review.



Mobile Support

Instron offers access to a troubleshooting tool that can help you self-diagnose issues with easy-to-follow steps created by our technical experts.



Training

Training courses are available on-site, regionally, at an Instron factory, or online. Utilize our Applications Engineering Lab or Custom Solutions Group for all the latest technological advances in materials testing.



Calibration

Our state-of-the-art Calibration Laboratory offers a comprehensive range of accredited calibration and verification services complying with ASTM, ISO, and Nadcap standards for force, speed, strain (extensometers), displacement, impact, temperature, torque, creep, strain gauge channel, and alignment.



On-Site Services

When on-site assistance is needed, our team of 300+ global Field Service Engineers can help get you back up and running. Our factory-trained technicians are located all around the world and speak 40+ languages to help solve problems no matter where they occur.

3400 SERIES SPECIFICATIONS

Single Columns

		34SC-05	34SC-1	34SC-2	34SC-5
Force Capacity	kN	0.5	1	2	5
	lbf	112	225	450	1125
Crosshead Travel	mm	482	867	867	868 (E1), 1112 (E2)
	in	19.0	34.1	34.1	34.2 (E1), 43.8 (E2)
Vertical Test Space (A)	mm	651	1050	1050	1118 (E1), 1375 (E2)
	in	25.6	41.3	41.3	44.0 (E1), 54.1 (E2)
Horizontal Test Space (B)	mm	100	100	100	100
	in	3.9	3.9	3.9	3.9
Maximum Speed	mm/min	1016	1016	1016	1016
	in/min	40	40	40	40
Minimum Speed	mm/min	0.05	0.05	0.05	0.05
	in/min	0.002	0.002	0.002	0.002
Maximum Return Speed	mm/min	1500	1500	1500	1500
	in/min	59	59	59	59
Footprint Dimensions (h × w × d)*	mm	950 × 460 × 610	1370 × 460 × 610	1370 × 460 × 610	1420 × 460 × 610
	in	37 × 18 × 24	54 × 18 × 24	54 × 18 × 24	56 × 18 × 24
Position Control Resolution	nm	125	125	125	125
	µin	4.92	4.92	4.92	4.92
Frame Axial Stiffness	kN/mm	2	2	2	8.5
	lb/in	11400	11400	11400	48500
Maximum Force at Full Speed	kN	0.5	1	2	5
	lbf	112	225	450	1125
Maximum Speed at Full Force	mm/min	1016	1016	1016	1016
	in/min	40	40	40	40
Weight	kg	50	54	54	63 (E1), 68 (E2)
	lb	110	120	120	138 (E1), 150 (E2)
Maximum Power Requirements	VA	256	256	256	366

* The footprint width is for the system only. The Operator Dashboard monitor may add 300 mm (12 in) to the overall width of the frame. The extra height (E2) option for the 34SC-5 adds 270 mm (11 in) to the overall height of the frame.

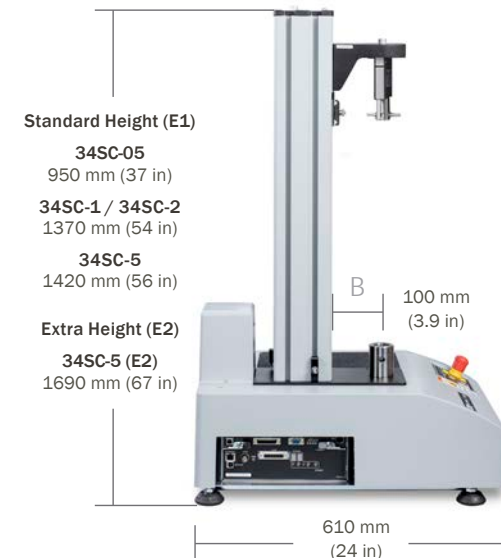

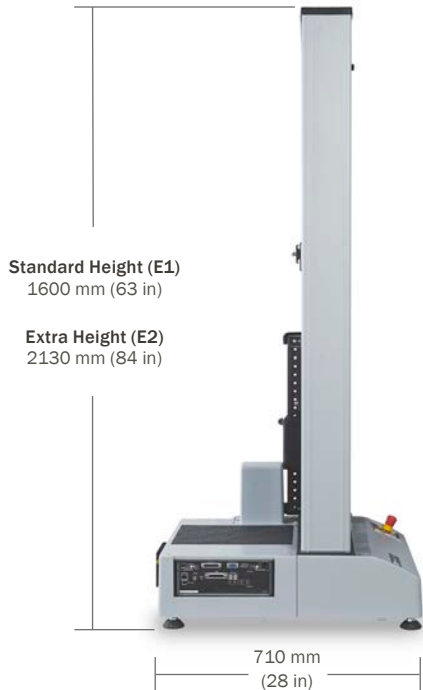
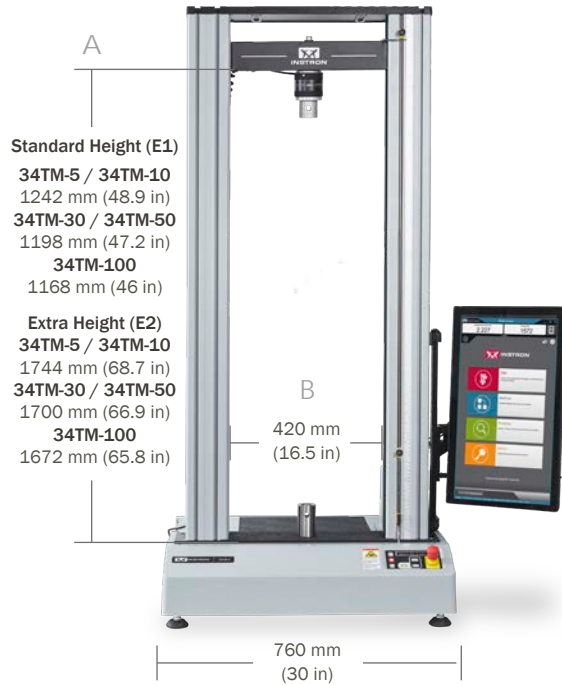

Table Models

		34TM-5	34TM-10	34TM-30	34TM-50	34TM-100
Force Capacity	kN	5	10	30	50	100
	lbf	1125	2250	6750	11250	22480
Crosshead Travel	mm	1172 (E1), 1651 (E2)	1172 (E1), 1651 (E2)	1128 (E1), 1607 (E2)	1128 (E1), 1607 (E2)	1097 (E1), 1582 (E2)
	in	46.1 (E1), 65.0 (E2)	46.1 (E1), 65.0 (E2)	44.4 (E1), 63.3 (E2)	44.4 (E1), 63.3 (E2)	43.2 (E1), 62.3 (E2)
Vertical Test Space (A)	mm	1242 (E1), 1744 (E2)	1242 (E1), 1744 (E2)	1198 (E1), 1700 (E2)	1198 (E1), 1700 (E2)	1168 (E1), 1672 (E2)
	in	48.9 (E1), 68.7 (E2)	48.9 (E1), 68.7 (E2)	47.2 (E1), 66.9 (E2)	47.2 (E1), 66.9 (E2)	46 (E1), 65.8 (E2)
Horizontal Test Space (B)	mm	420	420	420	420	420
	in	16.5	16.5	16.5	16.5	16.5
Maximum Speed	mm/min	1016	508	508	508	508
	in/min	40	20	20	20	20
Minimum Speed	mm/min	0.05	0.05	0.05	0.05	0.05
	in/min	0.002	0.002	0.002	0.002	0.002
Maximum Return Speed	mm/min	1500	610	610	508	508
	in/min	59	24	24	20	20
Footprint Dimensions (h x w x d)*	mm	1610 x 760 x 710	1610 x 760 x 710	1610 x 760 x 710	1610 x 760 x 710	1640 x 760 x 710
	in	63 x 30 x 28	63 x 30 x 28	63 x 30 x 28	63 x 30 x 28	65 x 30 x 28
Position Control Resolution	nm	129	64.7	33.8	24.1	16.78
	µin	5.09	2.55	1.33	0.95	0.66
Frame Axial Stiffness	kN/mm	38	38	72	74	180
	lb/in	217,000	217,000	411,100	422,000	1,027,000
Maximum Force at Full Speed	kN	5	10	30	25	50
	lbf	1125	2250	6750	5620	11250
Maximum Speed at Full Force	mm/min	1016	508	508	250	250
	in/min	40	20	20	10	10
Weight	kg	122 (E1), 136 (E2)	122 (E1), 136 (E2)	140 (E1), 154 (E2)	152 (E1), 166 (E2)	266 (E1), 295 (E2)
	lb	268 (E1), 299 (E2)	268 (E1), 299 (E2)	308 (E1), 339 (E2)	334 (E1), 365 (E2)	586 (E1), 650 (E2)
Maximum Power Requirements	VA	700	700	800	1100	1200

* The footprint width is for the system only. The Operator Dashboard monitor may add 300 mm (12 in) to the overall width of the frame. The extra height (E2) option adds 530 mm (21 in) to the overall height of the frame.

3400 SERIES SPECIFICATIONS

Floor Models

		34FM-100	34FM-300
Force Capacity	kN	100	300
	lbf	22480	67440
Crosshead Travel	mm	1407	1359
	in	55.3	53.5
Vertical Test Space (A)	mm	1494	1446
	in	58.8	56.9
Horizontal Test Space (B)	mm	575	575
	in	22.6	22.6
Maximum Speed	mm/min	508	508
	in/min	20	20
Minimum Speed	mm/min	0.00005	0.00005
	in/min	0.000002	0.000002
Maximum Return Speed	mm/min	600	508
	in/min	23.6	20.0
Footprint Dimensions (h x w x d)*	mm	2287 (B1), 2587 (B2) x 1140 x 786	
	in	90 (B1), 101.85 (B2) x 44.9 x 30.9	
Position Control Resolution	nm	2.215625	1.140395
	µin	0.087	0.044
Frame Axial Stiffness	kN/mm	300	350
	lb/in	1713044	2000000
Maximum Force at Full Speed	kN	50	125
	lbf	11240	28100
Maximum Speed at Full Force	mm/min	254	153
	in/min	10	6
Weight	kg	786.2 (B1), 848.4 (B2)	858.2 (B1), 920.3 (B2)
	lb	1733 (B1), 1870 (B2)	1892 (B1), 2029 (B2)
Maximum Power Requirements	VA	2400	3000



* Standard height and short base dimensions only. See diagrams for additional variations. The footprint width is for the system only. The Operator Dashboard monitor may add up to 500 mm (20 in) to the overall width of the frame.

| SPECIFICATIONS & REQUIREMENTS

Data Acquisition Rate at the PC:

Up to 1 kHz simultaneous on force, displacement, and strain channels

Load Measurement Accuracy:

±0.5% of reading down to 1/250th of load cell capacity

±1.0% of reading down to 1/500th of load cell capacity

Meets or exceeds ASTM E4, BS 1610, DIN 51221, ISO 7500-1, EN 10002-2, JIS B7721, JIS B7733, and AFNOR A03-501 standards.

Strain Measurement Accuracy:

Meets or exceeds ASTM E83, BS 3846, ISO 9513, and EN 10002-4 standards

Displacement Measurement Accuracy:

±0.02 mm or 0.15% of displacement (whichever is greater)

Testing Speed Accuracy:

(Zero or constant load) ±0.2% of set speed

Notes:

These specifications were developed in accordance with Instron's standard procedures and are subject to change without notice. All systems conform to all relevant European standards and carry a CE mark.

1. Applies to all 34SC and 34TM systems. 34FM systems support 208 to 240 VAC -5% / +10%.
2. Applies to 34FM-100 and 34FM-300 systems.

Single Phase Voltage¹:

100, 120, 220, or 240 VAC ±10%, 47 to 63 Hz

Three Phase Voltage²:

208 to 240 VAC -5% / +10%, 47 to 63 Hz

Operating Temperature:

+5 to +40 °C (+41 to +104 °F)

Storage Temperature:

-25 to +55 °C (-13 to +131 °F)

Ingress Protection (IP) Rating:

IP 2X. Protective measures may be required if excessive dust, corrosive fumes, electromagnetic fields, or hazardous conditions are encountered.

Humidity Range:

+10 to +90%, non-condensing at 20 °C



THE WORLD STANDARD

We stake our reputation on the integrity of data. From the measurement of primary test data to result generation, we design and manufacture the full data integrity chain (e.g. load cells, sensor conditioning, and software). Additionally, we calibrate more than 90,000 of these sensors annually with the lowest accumulated uncertainty.

30,000+

We service and calibrate more than 30,000 Instron systems in active use worldwide every year.

96%

96% of the Fortune 100 list of the world's largest manufacturing companies use Instron test systems.

18,000+

Instron systems have been cited in more than 18,000 patents since 1975.



Instron is a registered trademark of Illinois Tool Works Inc. (ITW). Other names, logos, icons and marks identifying Instron products and services referenced herein are trademarks of ITW and may not be used without the prior written permission of ITW. Other product and company names listed are trademarks or trade names of their respective companies. Copyright © 2025 Illinois Tool Works Inc. All rights reserved. All of the specifications shown in this document are subject to change without notice.