

8872 SERVOHYDRAULIC FATIGUE TESTING SYSTEM

25 kN

The Instron® 8872 is a compact tabletop servohydraulic testing system that meets the challenging demands of various static and dynamic testing requirements. With the actuator in the upper crosshead and a lower t-slot table, the 8872 makes an ideal platform for a variety of medical devices, biomaterials, advanced materials, and other component testing.

FEATURES AND BENEFITS

- Double-acting servohydraulic actuator with force capacity up to ± 25 kN (± 5620 lbf)
- High-stiffness, precision-aligned load frame with twin columns and actuator in upper crosshead
- 100 mm (4 in) of usable stroke
- Designed for both dynamic and static testing on a variety of materials and components
- Choice of hydraulic configuration and dynamic performance to suit application
- Adjustable upper crosshead with hydraulic lifts and manual locks fitted as standard for easy adjustment of daylight
- Patented₁ Dynacell™ load cell technology for faster testing and reduction of inertial errors
- Compact tabletop servohydraulic fatigue testing system – frame requires less than 0.4 m² (4.3 ft²) of space
- Designed to be used with the 3621 Series of Hydraulic Power Units
- Compatible with a large range of grips, fixtures, chambers, extensometers, protective shields, and other accessories
- Patented stiffness based tuning algorithm that enables users to tune a variety of specimens in seconds

CONTROLLER AND SOFTWARE

The Instron 8872 is supplied with a digital 8800MT controller that provides full system control including features such as stiffness based tuning, amplitude control, specimen protect, up to 24-bit resolution across the full range of transducers, and adaptive control technology. It also allows access to WaveMatrix™3 Dynamic Testing Software, Bluehill® Software for static tests and other application specific software, such as Bluehill Fracture.



FRAME SPECIFICATIONS

Daylight Opening (Maximum Between Load Cell and base at Mid-stroke)	mm	1067
	in	42
Dynamic Load Capacity	kN	±25
	lbf	±5620
Actuator Stroke (Total)	mm	100
	in	4
Configuration	Twin-Column High-Stiffness Load Frame with Actuator in Upper Crosshead and T-Slot Base	
Lifts and Locks	Hydraulically-Powered Lifts and Manual Locks	
Load Cell	Patented ¹ Dynacell™ Fatigue-Rated Load Cell with Capacity to Suit Actuator	
Load Weighing Accuracy	±0.5% of Indicated Load or ±0.005% of Load Cell Capacity (1-100%), Whichever is Greater	
Hydraulic Pressure Supply (Required)	bar	207
	psi	3000
Electrical Supply	Single-Phase Mains 90-132 or 180-264 VAC 45/65 Hz Power Consumption: 800 VA Max	
Operating Environment	+10 to +38°C (+50 to +100°F) with 10 to 90% Humidity Non-Condensing	
Frame Stiffness	kN/mm	260 (at 600 mm crosshead height)
	kg	287
Frame Weight	kg	287
	lb	633

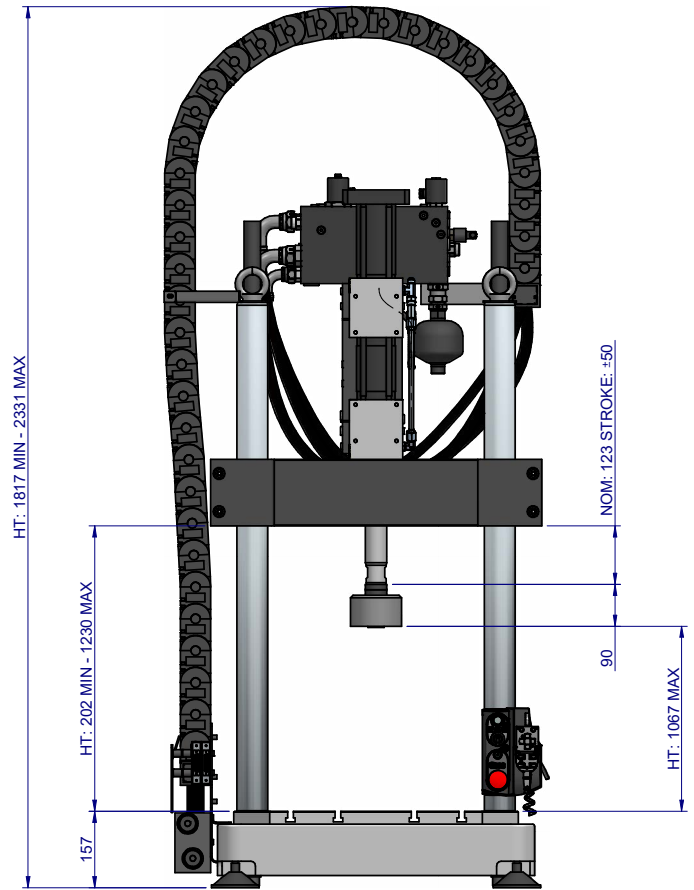

MECHANICAL INTERFACES

Load Cell	M20 × 1.5 Right Hand Central Thread
Actuator	M20 × 1.5 Right Hand Central Thread
Table and Crosshead	4 × M10 Holes on a 280 mm × 90 mm for Accessory Mounting
	6 × M10 on 100 mm PCD (Table) with 40 mm Location Diameter
	4 × M10 T-Slots Running Front and Back, Spaced 80 and 100 mm From Center Line

ACCESSORIES

2742-301	±30 kN Fatigue-Rated Hydraulic Wedge Grips
2780-118	Fracture Mechanics Grips for 12.5 mm Wide Compact Tension Specimen (±20kN static, ±10kN dynamic)
2810-181	3-Point Fatigue-Rated Bend Fixture (±100kN Dynamic)
2810-184	4-Point Conversion Kit for 2810-181
2840-119	150 mm (6 in) Diameter Compression Platens (500kN)

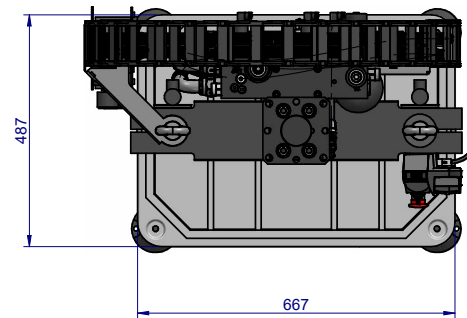

1) US Patent Number 6508132

Instron® 8872 Dimensions (All Dimensions in mm)
Drawings not to scale, for reference use only

www.instron.com



Worldwide Headquarters 825 University Ave,
Norwood, MA 02062-2643, USA Tel: +1 800 564
8378 or +1 781 575 5000

European Headquarters
Coronation Road, High Wycombe, Bucks HP12 3SY, UK
Tel: +44 1494 464646