

±1 kN PNEUMATIC FATIGUE-RATED WEDGE ACTION GRIPS

2742-103

Designed to suit ElectroPuls® test instruments, the 2742-103 pneumatic wedge action grips are suitable for tension, compression and reverse-stress testing on a wide range of specimens and materials. The grips are pneumatically operated directly from the machine handset and the open-fronted design provides easy specimen insertion, positioning and clamping.

PRINCIPLE OF OPERATION

The single-acting wedge action principle of these grips is designed to clamp a specimen without applying a compressive load, which could cause a specimen to buckle. The retracting movement of the grip bodies helps to reduce compressive loads that are normally caused when clamping specimens.

The open front design permits quick and easy changing of specimens and jaw faces. Jaw faces optimize gripping performance whilst the serrated faces are designed to minimize damage to the specimen surface.

APPLICATION RANGE

- Types of loading: Tension, compression or reverse-stress testing
- Specimen geometries: Flat or round specimens
- Specimen material: Metallics, plastics, composites, biomaterials
- Temperature range: +10 to +38 °C (50 to 100 °F)



±1 kN pneumatic
fatigue-rated wedge action grips

FEATURES

- Dynamic Linear Capacity: ±1 kN (±225 lbf)
- Independent upper and lower jaw faces opening and closing via the handset
- Enhanced usability thanks to software feedback of grip status
- Enhanced control and repeatability of specimen gripping
- Suitable for tension and compression, including full reverse-stress dynamic testing
- Open-fronted design for quick and easy specimen insertion from the front
- Self-tightening, moving body wedge design eliminates slippage and prevents specimen loading
- Interchangeable jaw faces for gripping different materials and specimen geometries and sizes

SPECIFICATIONS

Catalogue Number		2742-103
Maximum Force Capacity	kN	±1
	lbf	±225
Grip Mass	kg	0.85
	lbs	1.87
A	mm	73
	in	
B	mm	138
	in	
C	mm	128
	in	
D	mm	15
	in	
E	mm	22
	in	

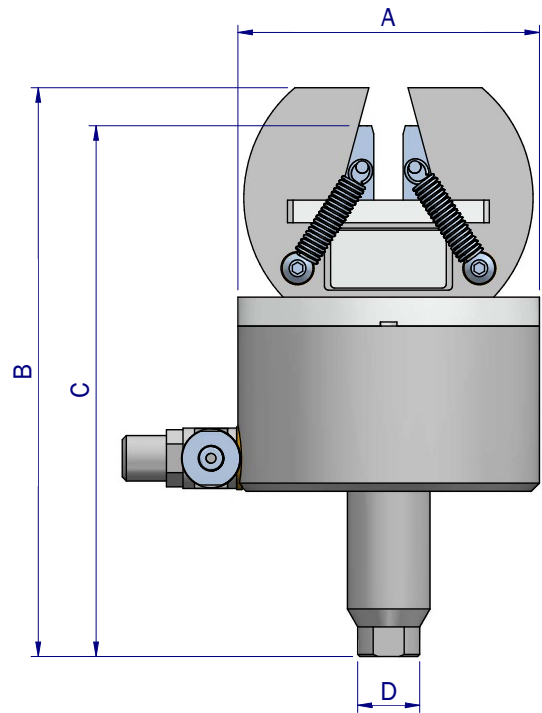

COMPATIBLE ACCESSORIES

2718-013

Pneumatic Air Kit for ElectroPuls Test

JAW FACES

Catalog Number	Specimen Type	Specimen Thickness		Clamping Area (W x H)
		mm	in	
2703-901	Flat	0 to 6.35	0 to 0.25	19 mm x 19 mm (0.7 in x 0.7 in)
2703-902	Round	∅ 3.0 to 7.8	0.12 to 0.31	19 mm x 19 mm (0.7 in x 0.7 in)

- Notes:
1. Jaw face catalogue number provides four faces
 2. Jaw faces are hardened to 48 to 52 Rc, unless otherwise specified
 3. All faces are diamond serrated 45°

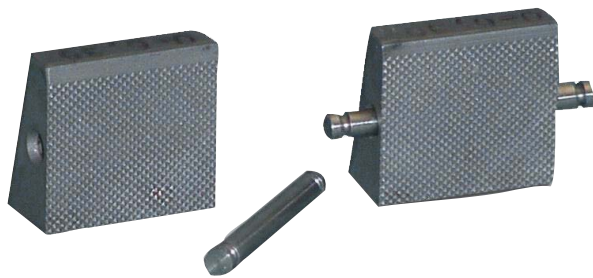

Flat Serrated Jaw Faces

Grip Dimensions

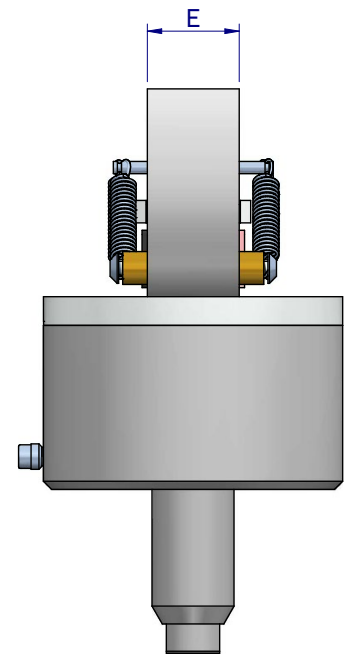

www.instron.com



Worldwide Headquarters
825 University Ave, Norwood, MA 02062-2643, USA
Tel: +1 800 564 8378 or +1 781 575 5000

European Headquarters
Coronation Road, High Wycombe, Bucks HP12 3SY, UK
Tel: +44 1494 464646

CEAST Headquarters
Via Airauda 12, 10044 Pianezza TO, Italy
Tel: +39 011 968 5511